

HP 3563A Installation Guide

Control Systems Analyzer

Serial Numbers
2927A00100



HP Part No. 03563-90007
Microfiche No. 03563-90207

Printed in U.S.A.

Print Date: October 1989

©Hewlett-Packard Company, 1989. All rights reserved.
8600 Soper Hill Road
Everett, Washington 98205-1298 U.S.A.



CERTIFICATION

Hewlett-Packard Company certifies that this product met its published specifications at the time of shipment from the factory. Hewlett-Packard further certifies that its calibration measurements are traceable to the United States National Bureau of Standards, to the extent allowed by the Bureau's calibration facility, and the calibration facilities of other International Standards Organization Members.

WARRANTY

This Hewlett-Packard product is warranted against defects in material and workmanship for a period of one year from date of shipment. During the warranty period, Hewlett-Packard Company will, at its option, either repair or replace products which prove to be defective.

For warranty service or repair, this product must be returned to a service facility designated by -hp-. Buyer shall prepay shipping charges to -hp- and -hp- shall pay shipping charges to return the product to Buyer. However, Buyer shall pay all shipping charges, duties, and taxes for products returned to -hp- from another country.

HP software and firmware products which are designated by HP for use with a hardware product, when properly installed on the hardware product, are warranted not to fail to execute their programming instructions due to defects in materials and workmanship. If HP receives notice of such defects during their warranty period, HP shall repair or replace software media and firmware which do not execute their programming instructions due to such defects. HP does not warrant that the operation of the software, firmware or hardware shall be uninterrupted or error free.

LIMITATION OF WARRANTY

The foregoing warranty shall not apply to defects resulting from improper or inadequate maintenance by Buyer, Buyer-supplied software or interfacing, unauthorized modification or misuse, operation outside of the environmental specifications for the product, or improper site preparation or maintenance.

NO OTHER WARRANTY IS EXPRESSED OR IMPLIED. HEWLETT-PACKARD SPECIFICALLY DISCLAIMS THE IMPLIED WARRANTIES OF MERCHANTABILITY AND FITNESS FOR PARTICULAR PURPOSE.

EXCLUSIVE REMEDIES

THE REMEDIES PROVIDED HEREIN ARE BUYER'S SOLE AND EXCLUSIVE REMEDIES. HEWLETT-PACKARD SHALL NOT BE LIABLE FOR ANY DIRECT, INDIRECT, SPECIAL, INCIDENTAL, OR CONSEQUENTIAL DAMAGES, WHETHER BASED ON CONTRACT, TORT, OR ANY OTHER LEGAL THEORY.

ASSISTANCE

Product maintenance agreements and other customer assistance agreements are available for Hewlett-Packard products.

For any assistance, contact your nearest Hewlett-Packard Sales and Service Office. Addresses are provided at the back of this manual.



SAFETY SUMMARY

The following general safety precautions must be observed during all phases of operation, service, and repair of this instrument. Failure to comply with these precautions or with specific warnings elsewhere in this manual violates safety standards of design, manufacture, and intended use of the instrument. Hewlett-Packard Company assumes no liability for the customer's failure to comply with these requirements. This is a Safety Class 1 instrument.

GROUND THE INSTRUMENT

To minimize shock hazard, the instrument chassis and cabinet must be connected to an electrical ground. The instrument is equipped with a three-conductor ac power cable. The power cable must either be plugged into an approved three-contact electrical outlet or used with a three-contact to two-contact adapter with the grounding wire (green) firmly connected to an electrical ground (safety ground) at the power outlet. The power jack and mating plug of the power cable meet International Electrotechnical Commission (IEC) safety standards.

DO NOT OPERATE IN AN EXPLOSIVE ATMOSPHERE

Do not operate the instrument in the presence of flammable gases or fumes. Operation of any electrical instrument in such an environment constitutes a definite safety hazard.

KEEP AWAY FROM LIVE CIRCUITS

Operating personnel must not remove instrument covers. Component replacement and internal adjustments must be made by qualified maintenance personnel. Do not replace components with power cable connected. Under certain conditions, dangerous voltages may exist even with the power cable removed. To avoid injuries, always disconnect power and discharge circuits before touching them.

DO NOT SERVICE OR ADJUST ALONE

Do not attempt internal service or adjustment unless another person, capable of rendering first aid and resuscitation, is present.

DO NOT SUBSTITUTE PARTS OR MODIFY INSTRUMENT

Because of the danger of introducing additional hazards, do not install substitute parts or perform any unauthorized modification to the instrument. Return the instrument to a Hewlett-Packard Sales and Service Office for service and repair to ensure the safety features are maintained.

DANGEROUS PROCEDURE WARNINGS

Warnings, such as the example below, precede potentially dangerous procedures throughout this manual. Instructions contained in the warnings must be followed.

Warning



Dangerous voltages, capable of causing death, are present in this instrument. Use extreme caution when handling, testing, and adjusting.

SAFETY SYMBOLS

General Definitions of Safety Symbols Used On Equipment or In Manuals.



Instruction manual symbol: the product will be marked with this symbol when it is necessary for the user to refer to the instruction manual in order to protect against damage to the instrument.



Indicates dangerous voltage (terminals fed from the interior by voltage exceeding 1000 volts must be so marked.)

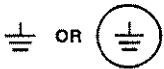

Protective conductor terminal. For protection against electrical shock in case of a fault. Used with field wiring terminals to indicate the terminal which must be connected to ground before operating equipment.



Low-noise or noiseless, clean ground (earth) terminal. Used for a signal common, as well as providing protection against electrical shock in case of a fault. A terminal marked with this symbol must be connected to ground in the manner described in the installation (operating) manual, and before operating the equipment.



Frame or chassis terminal. A connection to the frame (chassis) of the equipment which normally includes all exposed metal structures.



Alternating current (power line.)



Direct current (power line.)



Alternating or direct current (power line.)

Warning



The **WARNING** sign denotes a hazard. It calls attention to a procedure, practice, condition or the like, which if not correctly performed or adhered to, could result in injury or death to personnel.

Caution



The **CAUTION** sign denotes a hazard. It calls attention to an operating procedure, practice, condition or the like, which, if not correctly performed or adhered to, could result in damage to or destruction of part or all of the product.

Note



The **NOTE** sign denotes important information. It calls attention to procedure, practice, condition or the like, which is essential to highlight.

Table of Contents

Chapter 1: Introduction

About This Guide	1-2
Options	1-2
Accessories	1-3
Identification	1-4
Serial Numbers	1-4
Software Revision Code	1-4
Documentation Set	1-5

Chapter 2: HP 3563A Specifications

Frequency	2-1
Measurement Functions	2-1
Amplitude	2-2
Digital Inputs	2-3
Analog Inputs	2-3
Phase	2-3
Analog Source	2-4
Digital Source	2-4
Trigger	2-4
General	2-5

Chapter 3: Operation Verification Tests

Test Duration	3-1
Operation Verification Test List	3-1
Recommended Test Equipment	3-2
Initial Equipment Setup	3-3
How To Perform An Operation Verification Test	3-4
Conventions	3-4
Procedure	3-6
1. Self Test	3-7
2. DC Offset	3-8
3. Amplitude Accuracy And Flatness	3-11
4. Amplitude and Phase Match	3-15
5. Frequency Accuracy	3-22
6. Common Mode Rejection	3-24
7. Single Channel Phase Accuracy	3-29
8. Noise and Spurious Signal Level	3-33
9. Source Amplitude Accuracy and Flatness	3-39
Operational Verification Test Record	3-42

Table of Contents

Chapter 4: Performance Tests

Test Duration	4-1
Calibration Cycle	4-1
Tested Specifications	4-2
Recommended Test Equipment	4-2
Initial Equipment Setup	4-6
How To Perform A Performance Test	4-7
Conventions	4-7
Procedure	4-9
1. Self Test	4-10
2. DC Offset	4-11
3. Amplitude Accuracy and Flatness	4-14
Amplitude Accuracy and Flatness Measurement One	4-17
Amplitude Accuracy and Flatness Measurement Two	4-19
Amplitude Accuracy and Flatness Measurement Three	4-21
4. Amplitude Linearity	4-23
5. Amplitude and Phase Match	4-28
6. Anti-Alias Filter Response	4-36
7. Frequency Accuracy	4-39
8. Input Coupling Insertion Loss	4-42
9. Single Channel Phase Accuracy	4-47
10. Digital Input/Output	4-51
Alternate Setup for Digital Input/Output Test	4-54
11. Input Impedance	4-58
Input Resistance Test	4-60
Input Capacitance Test	4-62
12. Harmonic Distortion	4-66
Harmonic Distortion Test One	4-67
Harmonic Distortion Test Two	4-71
13. Intermodulation Distortion	4-74
Intermodulation Distortion Test Measurement One	4-76
Intermodulation Distortion Test Measurement Two	4-80
14. Noise and Spurious Signal Level	4-84
15. Cross Talk	4-90
Cross Talk Channel 1 Test	4-90
Cross Talk Channel 2 Test	4-93
16. Common Mode Rejection	4-95
17. External Reference Test	4-100
18. Source Residual Offset	4-102
19. Source Amplitude Accuracy and Flatness	4-104
20. Source Distortion	4-106
21. Source Energy Measurement	4-109
Performance Test Record	4-114

Chapter 5: Installation

Safety Considerations	5-2
Incoming Tests	5-2

Table of Contents

Dimensions and Weight	5-2
Power Requirements	5-3
Power Cable and Grounding Requirements	5-5
Power Cable	5-5
Grounding	5-7
Operator Maintenance	5-7
Cleaning the Air Filter	5-8
Cleaning the Display (CRT)	5-8
Analyzer Cooling	5-9
Installation	5-9
Turning on the HP 3563A	5-9
HP-IB System Interface Connections	5-10
Labeling the Digital Probes and Cables	5-10
Labeling the Input Cables	
Qualifier Pod, Input Pod 1 and Input Pod 2	5-10
Labeling the Output Cables	
Pod X, Source Pod MSB and Source Pod LSB	5-12
Operating Environment	5-14
Storage and Shipment	5-15

Introduction

The HP 3563A

The HP 3563A Control Systems Analyzer is dual-channel FFT-based analyzer. The HP 3563A can perform time, spectrum and frequency-response measurements on analog signals from dc to 100 kHz. The same measurements can be made on digital signals with sample rates up to 256 kHz. Besides linear and logarithmic resolution measurement modes, the HP 3563A also provides swept sine measurements.

The analysis features of this instrument provide the flexibility to manipulate the gathered data into almost any format required through waveform math, frequency response synthesis, and curve fitting routines.

The HP 3563A has a pair of differential input channels and a built-in signal source. It is capable of two channel measurements, with any mix of analog or digital data on any channel. This analyzer also drives HP-GL plotters without a controller. External disc drives can be driven directly for data and instrument state storage.

About This Guide

The HP 3563A Installation Guide contains installation and operating information, along with the operation verification tests and performance tests. It is included in the HP 3563A Documentation Set, as well as with the optional *HP 3563A Service Manual*.

This book is organized with the specifications, operation verification tests, and the performance tests near the beginning and the installation information at the back of the guide.

Options

There are eight options available for the HP 3563A. They are available either when the instrument is ordered, or they may be installed later. These options are listed in Table 1-1.

Table 1-1. HP 3563A Options

Option	Description	Part Number
907	Front Handle Kit	5061-0091
908	Rack Mount Kit	5061-0079
909	Rack Mount and Front Handle Kit	5061-0085
910	Extra Operating Manuals (1 set)	*
915	Service Manual	03563-90006
921	PC File Utilities	
	3.5* disk	03563-19400
	5.25* disk	03563-19401
922	Delete Cables	
923	Add Cables	*

* May be ordered by individual part number.

Accessories

The following accessories are supplied with the HP 3563A:

Line Power Cord	See Figure 5-2
Pouch	HP 1540-1199
Operating Manual	HP 03563-90000
Installation Guide	HP 03563-90007
Getting Started Guide	HP 03563-90001
Application Note 243: The Fundamentals of Signal Analysis	HP 5952-8898
Application Note 243-2 : Control System Development Using Dynamic Signal Analyzers	HP 5958-5136 *
Application Note 243-4: Fundamentals of Z-Domain and Mixed Analog/Digital Measurements	HP 5952-7250 *
Curve Fitting in the HP 3562A	HP 5952-0001 *
Z-Domain Curve Fitting in the HP 3563A	HP 5952-7251 *
Programming Reference	HP 03563-90005
16 Bit Probe Cable	HP 01650-61607
16 Bit Probe Pod	HP 01650-61605
8 Bit Probe Cable	HP 03563-61604
Grabber	HP 5959-0288
Pattern Generator Probe Lead Set	HP 10347A

* Available from your local Hewlett-Packard sales and service office.

The following accessories are available:

8 Channel TTL Tristate Buffer Pod	HP 10346A
Service Kit	HP 03563-84401
Termination Adapter	HP 01650-63201
Transit Case	HP 9211-2663

Note



The Service Kit, 03563-84401, as well as the Service Manual, HP 03563-90006, are required to service the HP 3563A.

Identification

Serial Numbers

This guide applies to analyzers with the serial number prefixes listed under Serial Numbers on the title page.

Hewlett-Packard makes frequent improvements to its products to enhance their performance, usability, or reliability, and to control costs. HP service personnel have access to complete records for each type of equipment, based on the equipment's serial number. Whenever you contact HP about your HP 3563A, have the complete serial number available to ensure obtaining the most complete and accurate information possible.

A serial number label is attached to the rear of the analyzer. The serial number has two parts: the prefix (the first four numbers and a letter), and the suffix (the last five numbers).

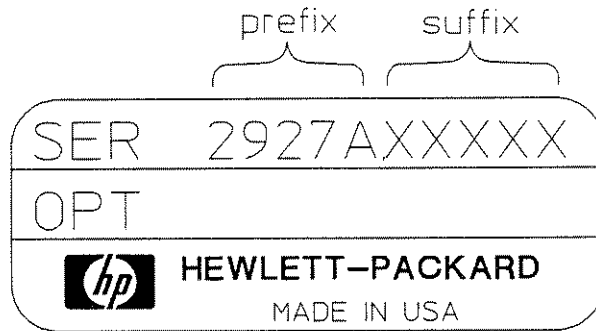

Figure 1-1. HP 3563A Serial Number

Software Revision Code

As with changes to the instrument hardware, Hewlett-Packard makes changes to its software. To determine which version of software is in your analyzer, press the following keys:

[Control]			
SPCL		SERVIC	TEST
FCTN	TEST	RESULT
		
			FAULT
			LOG

The revision number is listed under the Fault Log display title.

Documentation Set

The contents of this guide apply to those instruments having the same serial number prefix as listed on the title page.

Instruments manufactured after the printing of this documentation set may have a serial number prefix which is not listed on the title page. This unlisted prefix indicates that the instrument is different from those documented in the documentation set. A yellow "Manual Changes" supplement which contains information documenting the differences may be included with a manual. In addition to instrument change information, the supplement may contain information for correcting the manual. To keep this documentation set as accurate as possible, Hewlett-Packard recommends that you periodically request the latest "Manual Changes" supplement.

Listed on the title page is a part number. This part number can be used to order extra copies of the installation guide. The microfiche part number can be used to order 4 by 6 inch microfilm transparencies of this guide.

1
2
3
4
5
6
7
8
9
10
11
12
13
14
15
16
17
18
19
20
21
22
23
24
25
26
27
28
29
30
31
32
33
34
35
36
37
38
39
40
41
42
43
44
45
46
47
48
49
50
51
52
53
54
55
56
57
58
59
60
61
62
63
64
65
66
67
68
69
70
71
72
73
74
75
76
77
78
79
80
81
82
83
84
85
86
87
88
89
90
91
92
93
94
95
96
97
98
99
100

HP 3563A Specifications

Specifications describe the instrument's warranted performance. Supplemental characteristics are given as typical, but not warranted, performance figures and are intended to provide information useful in applying the instrument. These characteristics are denoted as 'typical,' 'nominal,' or 'approximately.'

Measurement Functions

The following table lists the functions the analyzer can measure directly based on the selected measurement mode. These measurements can be made with either analog or digital input signals.

Frequency

Measurement Range:
64 μ Hz to 100 kHz. Both channels, single- or dual-channel operation.

Accuracy: $\pm 0.004\%$ of frequency reading.

Resolution: Span/800. Both channels, single- or dual-channel operation, Linear Resolution mode.

Spans:

	BaseBand	Zoom
# of spans	66	64
min span	10.24 mHz	20.48 mHz
max span	100 kHz	100 kHz
time record (sec)	800/span	800/span

Window Functions: Flat Top, Hann, Uniform, Force, Exponential and User Defined.

Window Parameters:

	FlatTop	Hann	Uniform
Noise Equiv BW (% of span)	0.478	0.188	0.125
3 dB BW (% of span)	0.45	0.185	0.125
Shape factor	2.6	9.1	716

Typical Real Time Bandwidths:

Single-channel, fast averaging	10.00 kHz
Single-channel, single display	2.50 kHz
Dual-channel, fast averaging	5.00 kHz
Dual-channel, single display	2.00 kHz
Throughput to CS/80 disk	
Single-channel	12.50 kHz
Dual-channel	6.25 kHz

Time Domain Measurement

	Linear Resolution	Logarithmic Resolution	Swept Sine	Time Capture
Filtered Time Record	X			X
Compressed Time Buffer (1 to 10 records, chan 1 or 2)				X
Orbits (chan 1 versus chan 2)	X			
Input Time Record (full span, chans 1 and 2)	X	X	X	X
Auto Correlation (chans 1 and 2)	X			
Cross Correlation	X			
Impulse Response	X			

Frequency Domain Measurements

	Linear Resolution	Logarithmic Resolution	Swept Sine	Time Capture
Input Linear Spectrum (full span, chans 1 and 2)	X	X	X	X
Filtered Linear Spectrum (chans 1 and 2)	X			X
Power Spectrum (chans 1 and 2)	X	X	X	X
Power Spectral Density (PSD, chans 1 and 2)	X	X		X
Square Root of PSD (chans 1 and 2)	X	X		X
Energy Spectral Density (ESD, chans 1 and 2)	X			X
Cross Power Spectrum	X	X	X	
Frequency Response (linear frequency spacing)	X		X	
Frequency Response (logarithmic frequency spacing)		X	X	
Coherence Function (with averaging)	X	X		

Amplitude Domain Measurements

	Linear Resolution	Logarithmic Resolution	Swept Sine	Time Capture
Histogram (chans 1 and 2)	X			X
Probability Density Function (PDF, chans 1 and 2)	X			X
Cumulative Density Function (CDF, chans 1 and 2)	X			X

Demodulation is a valid preprocessing function for all linear resolution measurements when zooming. All linear and log resolution

measurements can be performed on time throughput data with the exception of full span linear spectrum and input time record.

Amplitude

Accuracy: Defined as full scale accuracy at any of the calculated frequency points. Overall accuracy for the Linear or Logarithmic Resolution modes is the sum of the absolute accuracy, window flatness and noise level. Overall accuracy for Swept Sine mode is the sum of absolute accuracy and noise level.

Input Connections: Cases 1 and 2 are the recommended input connections. For these cases, the amplitude accuracy specified below is applicable.

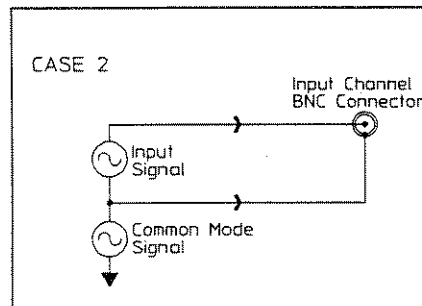
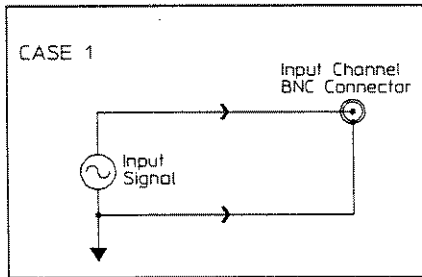

Cases 3 and 4 are input connections which degrade amplitude accuracy. For these cases the amplitude accuracy specified below must be modified with the accuracy adders.

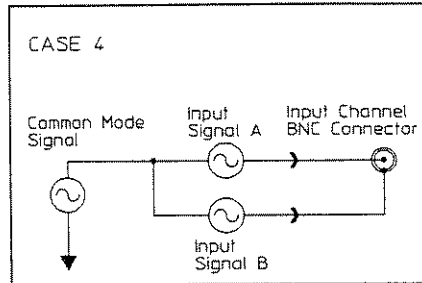
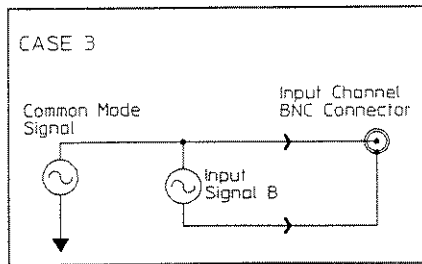

Absolute Accuracy: Single channel (Channel 1 or 2), input connections as shown in Case 1 or 2, above.

$\pm 0.15 \text{ dB} \pm 0.015\%$ of input range
 (+27 dBV to -40 dBV)
 $\pm 0.25 \text{ dB} \pm 0.025\%$ of input range
 (-41 dBV to -51 dBV)

DC Response:

Input Range (dBV rms)	dc Level
+27 to -35	> 30 dB below full scale
-36 to -51	> 20 dB below full scale

Frequency Response Channel

Match: Specified or nominal accuracy for analog/analog, digital/digital and mixed analog/digital measurements.

Analog/Analog: For input connections as shown in Case 1 or 2 above and input signals at full scale on any pair of ranges, accuracy is $\pm 0.1 \text{ dB}$, ± 0.5 degree.

Digital/Digital: For simultaneous sampling on channels 1 and 2, accuracy is $\pm 0.1 \text{ dB}$, ± 0.5 degree.

Mixed Analog/Digital: With full scale inputs on both channels, computational delay between channels corrected for, 1:1 sampling ratio, 256 kHz sample clock, 16 averages, nominal accuracy is

DC to 20 kHz $\pm .2 \text{ dB}$
 ± 1.0 degree
 20 kHz to 100 kHz $\pm .2 \text{ dB}$
 ± 4.0 degree

Single Channel Accuracy

Adder: Input connections as shown in Case 3 or 4 above. Add $\pm 0.35 \text{ dB}$ and ± 4.0 degrees to the absolute accuracy.

Dual Channel Accuracy Adder:

Add $\pm 0.35 \text{ dB}$ and ± 4.0 degrees once for each input connected as shown in Case 3 or 4 above.

Window Flatness:

Flat Top +0, -0.01 dB
 Hann +0, -1.5 dB
 Uniform +0, -4.0 dB

Effective Log Resolution Window Flatness: +1.72, -5.56 dB

Noise Floor: With flat top window, 50 Ω source impedance and input set to the -51 dBV range.

20 Hz to 1 kHz (1 kHz span)
 $< -126 \text{ dBV} (-134 \text{ dBV}/\sqrt{\text{Hz}})$
 1 kHz to 100 kHz (100 kHz span)
 $< -115 \text{ dBV} (-144 \text{ dBV}/\sqrt{\text{Hz}})$

Dynamic Range: All distortion (intermodulation and harmonic), spurious and alias products are $\geq 80 \text{ dB}$ below full scale input range (16 averages).

Phase

Accuracy: Single channel, inputs connected as shown in Case 1 or 2; referenced to the trigger point.
 <10 kHz ± 2.5 degrees
 10 kHz to 100 kHz ± 12.0 degrees

Analog Inputs

Input Impedance: 1 M Ω $\pm 5\%$ shunted by <100 pF.

Input Coupling: Inputs may be ac or dc coupled. Ac rolloff is < 3 dB at 1 Hz.

Crosstalk: -140 dB (50 Ω source, 50 Ω input termination, input connectors shielded).

Common Mode Rejection:
 0 Hz to 66 Hz 80 dB
 66 Hz to 500 Hz 65 dB

Common Mode Voltage: dc to 500 Hz.

Input Range (dBVrms)	Maximum (ac + dc)
+27 to -12	± 42.0 Vpeak
-13 to -51	± 18.0 Vpeak*

*For the -43 to -51 dBV input ranges common mode signal levels cannot exceed ± 18 Vpeak or (Input Range) + (10 dB), whichever is the lesser level.

Common Mode Voltage: 500 Hz to 100 kHz.
 The ac part of the signal is limited to 42 Vpeak or (Input Range) + (10 dB), whichever is the lesser level.

Common Mode Distortion: For the levels specified above, distortion of common mode signals will be less than the level of the rejected common mode signal.

External Trigger Input Impedance: Typically 50 k Ω $\pm 5\%$

External Sampling Input: TTL compatible input for signals ≤ 256 kHz (nominal maximum sampling rate).

External Reference Input:
 Input Frequencies: 1, 2, 5 or 10 MHz $\pm 0.01\%$
 Amplitude Range: 0 dBm to +20 dBm (50 Ω)

Digital Inputs

Three digital inputs are on the rear panel of the analyzer. Two of the inputs are for measurement data, the third is the input for data qualifier lines. Measurement data signals can be up to 16-bits wide and must be parallel data in two's complement or offset-binary format. To fit the internal data format of the analyzer, the user must select either truncation of unused upper bits or rounding of the three lowest bits for data more than 13-bits wide. The data qualifier input accepts 8 qualifier lines, a trigger, and one clock signal. Input level is TTL compatible.

Maximum Input: ± 30 Vpeak at probe tips.

Input Impedance: Nominally 100 k Ω and 8 pF at probe tips.

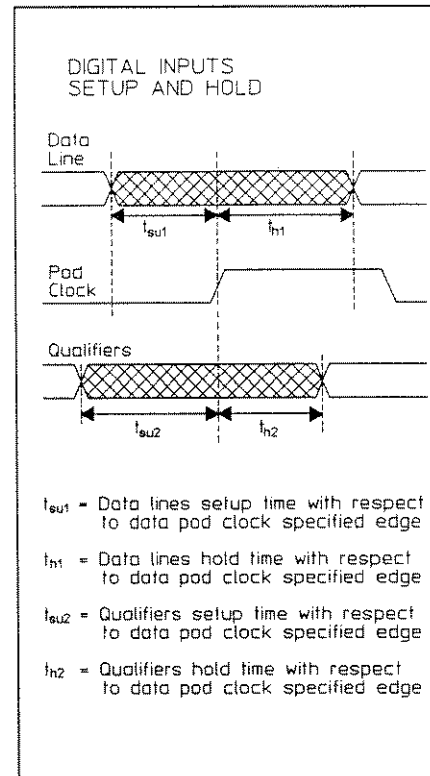

Data Lines:

Set Up Time: 20 ns with respect to data pod clock.
 Hold Time: 5 ns with respect to data pod clock.

Qualifier Lines:

Set Up Time: 60 ns with respect to data pod clock.
 Hold Time: 5 ns with respect to data pod clock.
 Hold Time (16 bit data with 8 bit bus): 15 ns with respect to data pod clock.

Clock Lines:

Minimum Qualified Sample Rate: 0.001 Hz
 Maximum Qualified Sample Rate: 256 kHz
 Minimum Pulse Width: 55 ns
 Maximum Clock Repetition Rate: 10 MHz
 Clock Rise/Falltime: <100 ns

Trigger

Trigger Modes: Free Run, Input Channel 1, Input Channel 2, Source and External Trigger. Free Run applies to all measurement modes. Input Channel 1, Input Channel 2, Source and External Trigger apply to the Linear Resolution, Time Capture and Time Throughput measurement modes.

Free Run: A new analog measurement is initiated by the completion of the previous measurement.

Input: A new measurement is initiated when the input to either Channel 1 or 2 meets the specified trigger conditions. Trigger level range is $\pm 110\%$ of full scale input range. Trigger level is user selected in steps of (input range in volts)/128.

Source: Measurements are synchronized with the periodic signal types (burst random, sine chirp, burst chirp, pulse, step, ramp, and arbitrary).

External: A new measurement is initiated by a signal applied to the front panel External Trigger input or the Digital Trigger port on the data qualifier pod. Analog trigger level range is nominally ± 10 V_{peak}; trigger level is user selected in 80 mV steps.

Trigger Delay: Pre- and post-trigger delay resolution is 1 sample (1/2048 of a time record).

Pre-Trigger: A measurement can be based on data that starts from 1 to 4096 samples (1/2048 to 2 time records) prior to trigger conditions being met.

Post-Trigger: A measurement is initiated from 1 to 65,536 samples (1/2048 to 32 time records) after triggering.

Analog Source

Random noise, burst random, sine chirp, burst chirp, fixed sine, swept sine, step, pulse, ramp and arbitrary signals are available from the front panel Source output. The random noise, burst random, sine chirp, burst chirp, and arbitrary signal types are band-limited and band-translated. DC offset is also user selectable.

Output Impedance: 50 Ω
(nominal)

Output Level: Between +10 and -10 V_{peak} (ac + dc) into a ≥ 10 k Ω , <1000 pF load. Maximum current is 20 mA.

AC Level: ± 5 V_{peak} (≥ 10 k Ω , <1000 pF load)

DC Offset: ± 10 V_{peak} in 100 mV steps. Residual offset at 0 V offset ≤ 10 mV.

Percent In-Band Energy: 1 kHz span, 5 kHz center frequency.
Random noise: 70%
Sine chirp: 85%

Accuracy and Purity: Fixed or swept sine.

Flatness:
dc to 65 kHz ± 1 dB
65 kHz to 100 kHz +1, -1.5 dB

Distortion: Including subharmonics
dc to 10 kHz -55 dB
10 kHz to 100 kHz -40 dB

Pulse: Nominally 1 sample wide and band-limited.

Digital Source

All of the analog signal types can be output from the digital source connector on the rear panel of the analyzer. Data format is 16-bit parallel in either two's complement or offset binary. Output level is TTL compatible.

Typical Transition Time: Low-to-high and high-to-low ≤ 20 ns

Maximum Load: 8 LSTTL

Maximum Output Rate: 256 kHz

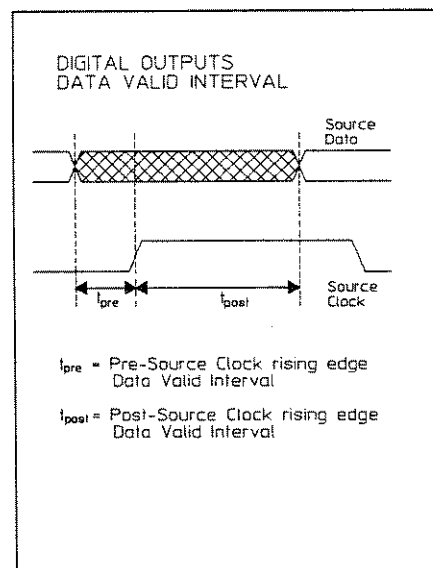

Source Output Data Valid:
With respect to clock rising edge.
Pre-clock ≥ 150 ns
Post-clock ≥ 3500 ns

General

Specifications apply when AUTO CAL is enabled or within 5°C and 2 hours of last internal calibration.

Ambient temperature:
0° to 55°C

Relative humidity:
≤ 95% at 40°C

Altitude: ≤ 4570 m (15,000 ft)

Storage:
Temperature: -40° to +75°C
Altitude: ≤ 15240 m (50,000 ft)

Power:
86-127 VAC, 48 to 66 Hz
195-253 VAC, 48 to 66 Hz
450 VA maximum

Weight:
27 kg (58 lbs) net
36 kg (79 lbs) shipping

Dimensions:
Height: 222 mm (8.75 in)
Width: 426 mm (16.75 in)
Depth: 578 mm (22.75 in)

HP-IB:
Implementation of IEEE Std
488-1978
SH1 AH1 T5 TE0 L4 LE0 SR1
RL1 PP0 DC1 DT1 C0
Supports the HP 91XX, 795X
and 796X families of disk drives.
Also supports Hewlett-Packard
Graphics Language (HP-GL)
digital plotters.

Operation Verification Tests

Introduction

This chapter contains the operation verification tests. These tests check selected specifications in their worst case conditions to provide a high level of confidence (90%) that the instrument is operating properly. These verification procedures should be used for incoming and after-repair inspections.

Test Duration

Operation Verification Tests take approximately two hours to complete.

Caution



Before applying line power to the analyzer or testing its electrical performance, see Chapter 5, "Installation."

Operation Verification Test List

Table 3-1 lists all the specifications and the corresponding operation verification tests.

Table 3-1. Specifications Versus Operation Verification Tests

Specification	Operation Verification Test
Measurement Hardware	Self Test
Residual dc Response	DC Offset
Absolute Accuracy	Amplitude Accuracy and Flatness
Frequency Response	Amplitude and Phase Match
Frequency	Frequency Accuracy
Common Signal Rejection	Common Mode Rejection
Phase Accuracy	Single Channel Phase Accuracy
Noise Floor	Noise and Spurious Signal Level

Recommended Test Equipment

The equipment needed to perform the HP 3563A operation verification tests is listed in Table 3-2. Other equipment may be substituted for the recommended model if it meets or exceeds the listed critical specifications. You may have to modify the procedures to accommodate the different operating characteristics if substitutions are made.

Table 3-2. Test Equipment

Instrument	Critical Specifications	Recommended Model
AC Calibrator	10 Hz to 100 kHz/ 1 mV to 10V Amplitude Accuracy: $\pm .1\%$ Phase Locking Capability	Fluke 5200A Alternative HP 745A Datron 4200
Two Channel Frequency Synthesizer	Frequency Range: 10 Hz to 1 MHz Frequency Accuracy: 10 ppm Amplitude Range: 40 Vp-p Amplitude Accuracy: ≤ 0.2 dB from 1 Hz to 100 kHz ≤ 1 dB from 100 kHz to 1 MHz Dynamic Range: ≤ -80 dBc, 10 Hz to 100 kHz	HP 3326A Opt 002 Alternative (2) HP 3325A / B Opt 001Opt 002
Feedthrough Terminations	(2) 50Ω : $\pm 2\%$ at dc (1) 600Ω : $\pm 2\%$ at dc	HP 11048C Alternative: Pomona Elect. Model 4119-50 HP 10100C HP 11095A Alternative: Pomona Elect. Model 4119-600
Cables	(2) BNC to BNC: length ≤ 30 cm Common Mode Cable (2) BNC/BNC Cable 122 cm (1) BNC/Dual Banana (1) Single Banana/Single Banana (2) Alligator Clip	HP 8120-1838 Alternative: HP 11170A HP 03562-61620 HP 8120-1840 HP 11001-60001 Pomona Elect. Model 2948-24-0 Pomona Elect. Model 1613-8-0
Adapters	(2) BNC TEE (m) (f) (f) (1) BNC (f) to BNC (f)	HP 1250-0781 HP 1250-0080

Initial Equipment Setup

When the recommended test equipment of Table 3-2 is used to complete the operational verification, the instruments listed below must be set to the preset conditions listed before beginning the test. In each test, any unspecified parameters should be set to the following conditions:

Frequency Synthesizer

Function	SINE WAVE (~)
Frequency	1 kHz
Amplitude	1 mVrms
Phase	0 Degrees
dc Offset	0V
Modulation	OFF
Sweep	OFF

AC Calibrator

Frequency	1 kHz
Amplitude01 Vrms
Voltage Error %	OFF
Vernier	0
Mode	OPER
Control	LOCAL
Phase Lock	OFF
Sense	INTERNAL

How To Perform An Operation Verification Test

Conventions

There are two types of keys on the HP 3563A, hardkeys and softkeys. Hardkeys are organized on the front panel according to functional group. See Figure 3-1. In these procedures, the functional group is in brackets, the hardkeys appear in bold text, and the softkeys are in regular text.

1. For example:

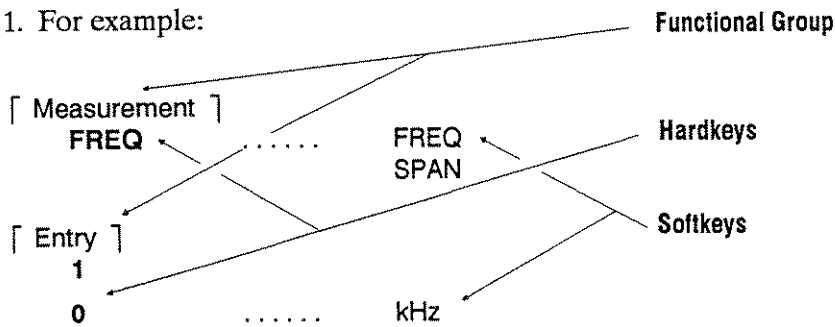

2. This example instructs you to first press the hardkey **FREQ** which is found in the Measurement group followed by the softkey **FREQ SPAN**. Next, enter the number 10 on the numeric keypad located in the Entry group. Specify the measurement unit by pressing the kHz softkey.

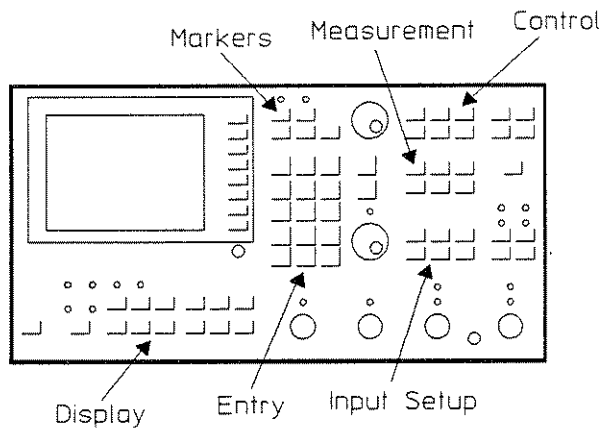

Figure 3-1. Front Panel Illustration

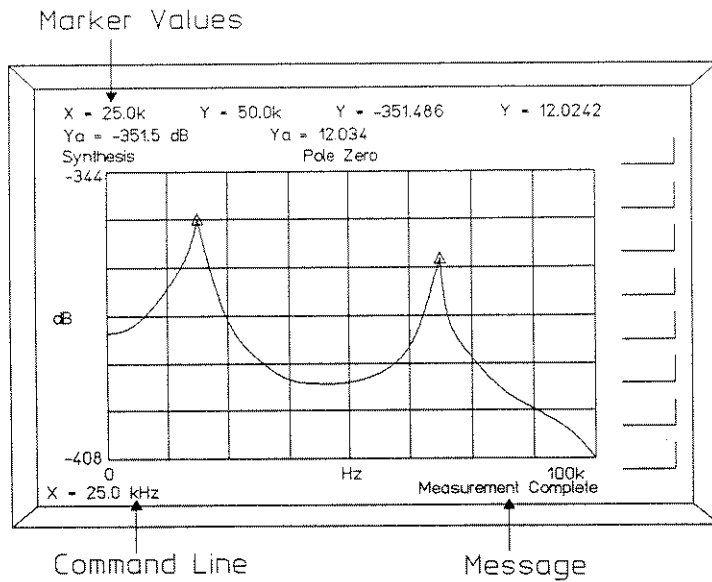

Figure 3-2. HP 3563A Display

Note



In the following test procedures, numeric values may require multiple keystrokes. In the previous example, the value 10 requires two keystrokes, 1 and 0. In the procedures, these keystrokes are represented as 10.

If you make an incorrect keystroke, press the previous hardkey. This will return you to a first level menu which allows you to continue with the procedure.

All tests must be performed with Automatic Calibration ON. When the instrument powers up, Auto Cal is on, **do not turn it off.**

Procedure

1. Start each operation verification test by setting the test equipment to the specified conditions. If no conditions are listed, set the test equipment to those listed in the preceding section, Initial Setup.
2. Enter the keys specified in the procedure.
3. Record the position of the X and Y markers as indicated for each test. Refer to Figure 3-2 for an example of the position of the X and Y marker readings. Additional information about reading the X and Y marker positions is available in the *HP 3563A Operating Reference Manual*.
4. Record the results of each test on the Operation Verification Test Record located at the end of this chapter. *This test record may be reproduced without written permission of Hewlett-Packard.*
5. If the HP 3563A fails a test, see the "If Test Fails" section at the end of each test.

Note



The instrument will not record any keystroke during a calibration cycle or a measurement. A status message appears in the lower-right corner of the display. Refer to Figure 3-2.

Note



To minimize the time required to change instrument configurations between tests, do the tests in the order shown.

1. Self Test

This test determines if the HP 3563A is operating correctly. No tests should be attempted until the instrument passes this test.

Required Test Equipment

None

Test Duration

This test takes about 1 minute to complete.

Procedure

1. Press the HP 3563A keys as follows:

[Control]				
SPCL	SELF	SELF
FCTN		TEST		TEST

2. During the Self Test cycle, the message "Diagnostic In Progress" will appear in the message area. Keystrokes are not recorded during calibration and measurements. You must wait until the measurement is completed.
3. When "Self Test Passes" is displayed in the lower right corner of the display, check PASS on the Operational Verification Test Record.

If Test Fails

If this test fails, contact your local Hewlett-Packard sales and service office or have a qualified service technician see the following sections in the *HP 3563A Service Manual*:

"Fault Isolation Section", Section VII.

2. DC Offset

This test measures the level of the dc offset generated with Auto Cal on.

Required Test Equipment

- 50Ω feedthrough terminations (2)
- Alligator Clip Cables

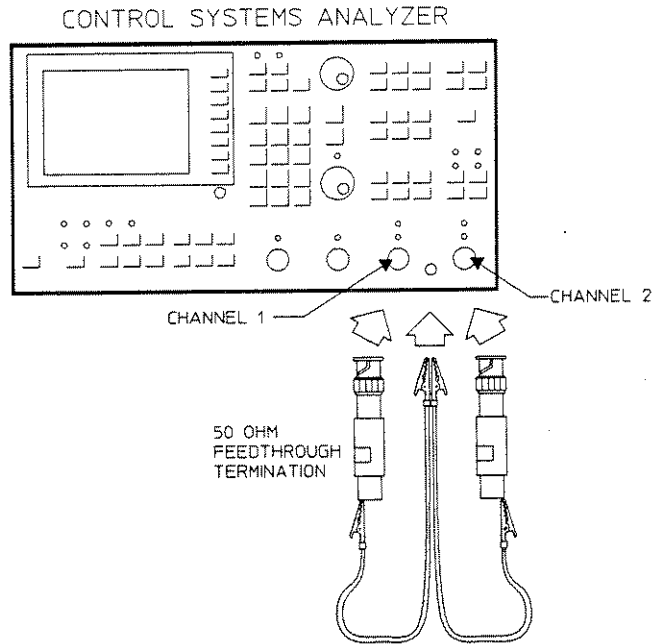

Figure 3-3. DC Offset Setup

Procedure

1. Connect the HP 3563A as shown in Figure 3-3. Keep the leads to chassis ground as short as possible.
2. Press the HP 3563A keys as follows:

[Control]				
PRESET	RESET		
[Input Setup]				
CAL	AUTO		
		ON		
	SINGLE		
		CAL		
[Measurement]				
WINDOW	UNIFRM		
[Measurement]				
AVG				
[Entry]				
2	ENTER	STABLE
[Measurement]				
FREQ				
[Entry]				
1	kHz		
[Display]				
UNITS	P SPEC	VOLTS
		UNITS		RMS
			VOLTS
[Display]				
A&B				

Operation Verification Tests

2. DC Offset

[Markers]

X

.....

X

VALUE

[Entry]

0

.....

Hz

[Input Setup]

RANGE

[Entry]

-51

.....

dBVrms

[Control]

START

3. Record the Ya marker reading on the Operational Verification Test Record for the Channel 1 measured value.
4. Record the Yb marker reading on the Operational Verification Test Record for the Channel 2 measured value.

If Test Fails

If this test fails, contact your local Hewlett-Packard sales and service office or have a qualified service technician see the following sections in the *HP 3563A Service Manual*:

Adjustments
Section III

Track and Hold Offset Adjustment
Input DC Offset Adjustment

Troubleshooting
Section VIII

A33, A35 Input Boards
A32, A34 Analog Digital Converter Boards

3. Amplitude Accuracy And Flatness

This test measures the amplitude accuracy and flatness of the HP 3563A using the amplitude reference of the ac calibrator.

Required Test Equipment

- Frequency Synthesizer
- AC Calibrator
- Female to Female Barrel
- BNC Tee (m)(f)(f)
- BNC Cable (3)
- BNC (m) to dual banana
- Single Banana to Single Banana

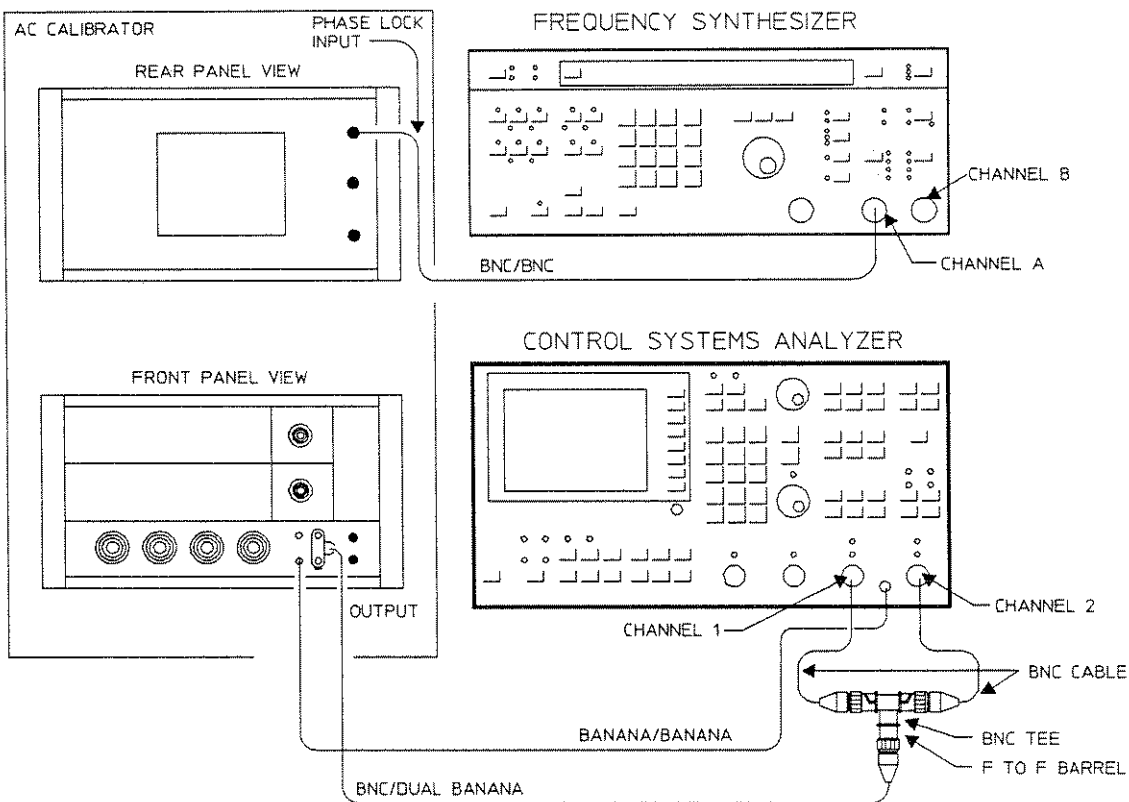

Figure 3-4. Amplitude Accuracy and Flatness Setup

3. Amplitude Accuracy And Flatness

Procedure

1. Connect the test instruments as shown in Figure 3-4.
2. Set the test instruments initially as follows:

Frequency Synthesizer

Function	SINE WAVE (~)
Frequency	1 kHz
Amplitude	1 Vrms
Phase	0 Degrees
dc Offset	0V
Modulation	OFF
Sweep	OFF

AC Calibrator

Frequency	1 kHz
Amplitude	2. 7698 Vrms
Voltage Error %	OFF
Vernier	0
Mode	OPER
Control	LOCAL
Phase Lock	ON
Sense	INTERNAL

3. Press the HP 3563A keys as follows:

[Control]
PRESET RESET

[Input Setup]
CAL SINGLE
CAL

[Measurement]
WINDOW FLAT
TOP

```
[ Measurement ]
  AVG

[ Entry ]
  4          .....  ENTER          .....  STABLE

[ Display ]
  UNITS      .....  P SPEC          .....  VOLTS
              UNITS              RMS
              .....  VOLTS

[ Display ]
  A&B
```

Table 3-3. Amplitude Accuracy and Flatness

HP 3563A Range Setting	Signal Frequency	AC Calibrator Amplitude	Lower Limit Specification	Upper Limit Specification
9 dBVrms	1 kHz	2.8184 Vrms	8.849 dBV	9.151 dBV
9 dBVrms	99 kHz	2.8184 Vrms	8.849 dBV	9.151 dBV
0 dBVrms	1 kHz	1.0000 Vrms	-.1513 dBV	.1513 dBV
0 dBVrms	99 kHz	1.0000 Vrms	-.1513 dBV	.1513 dBV
-13 dBVrms	1 kHz	.22387 Vrms	-13.15 dBV	-12.85 dBV
-13 dBVrms	99 kHz	.22387 Vrms	-13.15 dBV	-12.85 dBV

4. For each of the frequencies listed in Table 3-3 perform steps a through g:
- a. Press the HP 3563A keys as follows:

```
[ Input Setup ]
  RANGE          .....  To range setting in Table 3-3.

[ Measurement ]
  FREQ           .....  CENTER          To signal frequency in Table 3-3.
                   FREQ
```

- b. Set the AC Calibrator to the signal frequency specified in Table 3-3.
- c. Set the AC Calibrator's amplitude specified in Table 3-3.
- d. Set the Frequency Synthesizer to the signal frequency specified in Table 3-3.

Operation Verification Tests

3. Amplitude Accuracy And Flatness

e. Press the HP 3563A keys as follows:

[Control]
START

[Markers]
SPCL
MARKER MRKR →
PEAK

f. Record the Ya marker reading on the Operational Verification Test Record for Channel 1.

g. Record the Yb marker reading on the Operational Verification Test Record for Channel 2.

If Test Fails

If this test fails, contact your local Hewlett-Packard sales and service office or have a qualified service technician see the following sections in the *HP 3563A Service Manual*:

Adjustments
Section III

2nd Pass Gain Adjustment
ADC Offset and Reference Adjustment
Input Flatness Adjustment
Input Attenuator Adjustments
Calibrator Adjustment

Troubleshooting
Section VII

A33, A35 Input Boards
A32, A34 Analog Digital Converter Boards
A30 Analog Source Board

4. Amplitude and Phase Match

This test determines if the HP 3563A's amplitude and phase match between Channel 1 and Channel 2 are within the specified limits.

Required Test Equipment

- BNC to BNC: length ≤ 30 cm (2)
- BNC to BNC Cable
- Female to Female Barrel
- BNC Tee (m) (f) (f)

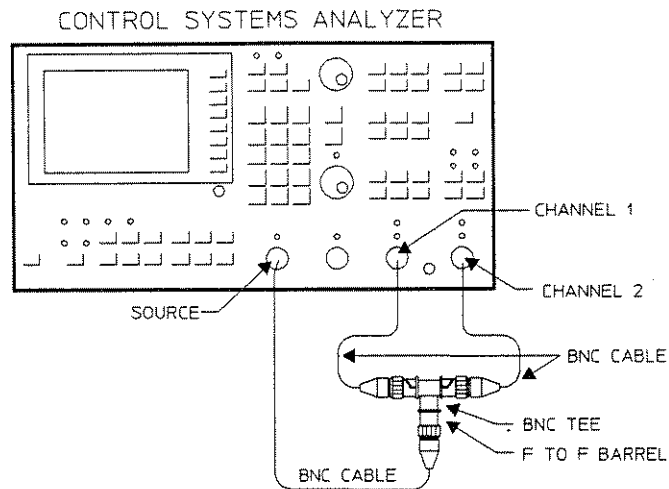

Figure 3-5. Amplitude and Phase Match Setup

Procedure

1. Connect the HP 3563A as shown in Figure 3-5. The cables to Channel 1 and Channel 2 must be the same length.
2. This test has six parts. Preset the HP 3563A by pressing the following keys:

[Control]				
PRESET	RESET		
[Input Setup]				
CAL	SINGLE		
		CAL		
[Input Setup]				
INPUT				
CONFIG	CHAN 1		
		AC		
	CHAN 2		
		AC		
	GROUND		
		CHAN 1		
	GROUND		
		CHAN 2		
[Input Setup]				
SELECT				
TRIG				
[Entry]				
0	V	SOURCE TRIG
[Measurement]				
WINDOW	UNIFRM		
		(NONE)		
[Measurement]				
AVG				
[Entry]				
16	ENTER	STABLE
[Measurement]				
SOURCE	SOURCE	PRIODC
		TYPE		CHIRP

[Display]
MEAS
DISP FREQ
RESP

[Display]
SCALE X FIXD
SCALE

[Entry]
.375, 100 kHz

3. Press the HP 3563A keys as follows:

[Input Setup]
RANGE AUTO 1 AUTO 2
UP & DWN UP & DWN

[Measurement]
SOURCE SOURCE
LEVEL

[Entry]
- 49 dBVrms

[Display]
SCALE Y FIXD
SCALE

[Entry]
- .2, .2 dB

[Control]
START

[Markers]
Y

[Entry]
- .1, .1 dB

4. Verify the measurement is within the marker band on the display. If it is, check PASS on the Operation Verification Test Record for Part 1.

Operation Verification Tests

4. Amplitude and Phase Match

5. Press the HP 3563A keys as follows:

[Measurement]
SOURCE SOURCE
LEVEL

[Entry]
0 dBVrms

[Control]
START

[Markers]
Y

[Entry]
-.1,.1 dB

6. Verify the measurement is within the marker band on the display. If it is, check PASS on the Operation Verification Test Record for Part 2.

7. Press the HP 3563A keys as follows:

[Measurement]
SOURCE SOURCE
LEVEL

[Entry]
10 dBVrms

[Control]
START

[Markers]
Y

[Entry]
-.1,.1 dB

8. Verify the measurement is within the marker band on the display. If it is, check PASS on the Operation Verification Test Record for Part 3.

9. Press the HP 3563A keys as follows:

[Input Setup]		
RANGE		
[Entry]		
-47	dBVrms
[Measurement]		
SOURCE	SOURCE LEVEL
[Entry]		
-49	dBVrms
[Display]		
COORD	PHASE
[Control]		
START		
[Display]		
SCALE	Y FIXD SCALE
[Entry]		
-1, 1	Degree
[Markers]		
Y	Y VALUE
[Entry]		
-.5, .5	Degree

10. If the measurement is within the marker band, check PASS on the Operation Verification Test Record for part 4.

[Control]
START

[Markers]
Y Y
VALUE

[Entry]
-.5, .5 degree

14. Verify the measurement is within the marker band on the display. If it is, check PASS on the Operation Verification Test Record for Part 6.

If Test Fails

If this test fails, contact your local Hewlett-Packard sales and service office or have a qualified service technician see the following sections in the *HP 3563A Service Manual*:

Adjustments
Section III

2nd Pass Gain Adjustment
ADC Offset and Reference Adjustment
Input Flatness Adjustment
Input Attenuator Adjustments
Calibrator Adjustment

Troubleshooting
Section VII

A33, A35 Input Boards
A32, A34 Analog Digital Converter Boards
A30 Analog Source Board

5. Frequency Accuracy

This test measures the frequency accuracy of the HP 3563A.

Required Test Equipment

Frequency Synthesizer
50Ω feedthrough termination
BNC to BNC Cable

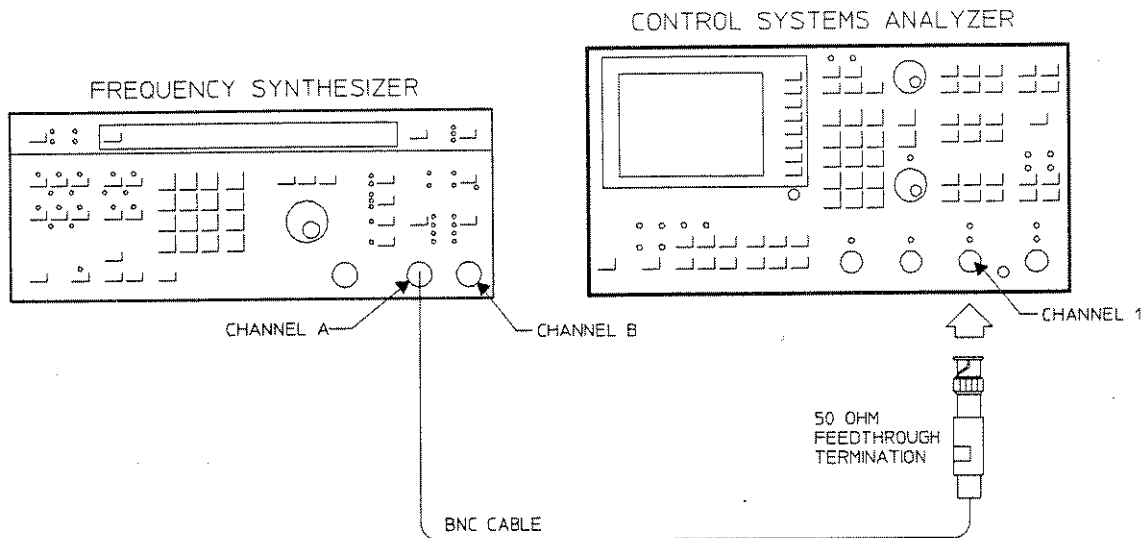

Figure 3-6. Frequency Accuracy Setup

Procedure

1. Connect the test equipment as shown in Figure 3-6.
2. Set the test instrument as follows:

Frequency Synthesizer

Function	SINE WAVE (~)
Frequency	99 kHz
Amplitude	1 Vrms
Phase	0 Degrees
dc Offset	0V
Modulation	OFF
Sweep	OFF

3. Press the HP 3563A keys as follows:

[Control]
PRESET RESET

[Input Setup]
CAL SINGLE
CAL

[Input Setup]
RANGE

[Entry]
0 dBVrms

[Measurement]
FREQ CENTER
FREQ

[Entry]
99 kHz

[Measurement]
AVG

[Entry]
2 ENTER STABLE

[Control]
START

[Markers]
X

4. Record the X marker reading as the measured value on the Operational Verification Test Record.

If Test Fails

If this test fails, contact your local Hewlett-Packard sales and service office or have a qualified service technician see the following sections in the *HP 3563A Service Manual*:

Adjustments	20.48 MHz Reference Adjustment Section III
Troubleshooting	A31 Trigger Board Section VII

6. Common Mode Rejection

This test measures the capability of the HP 3563A to ignore a signal which appears simultaneously and in phase at the high and low input of a single channel.

Required Test Equipment

Frequency Synthesizer
BNC to BNC: length ≤ 30 cm (2)
Common Mode Cable
BNC to BNC Cable
Alligator Cable
BNC (m) (f) (f)
Female to Female Barrel

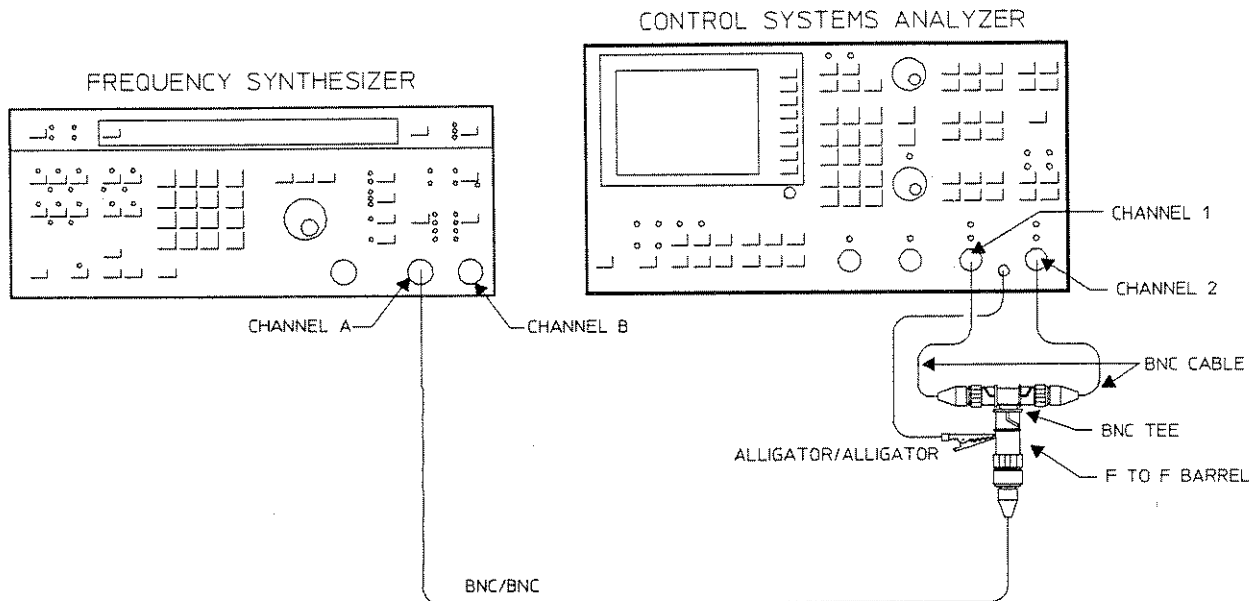

Figure 3-7. Common Mode Rejection Setup #1

Note



If Common Mode Cable is not available for Setup # 2, use the alternate setup, Figure 3-9.

Procedure

1. Connect the test instruments as shown in Figure 3-7.
2. Set the Frequency Synthesizer as follows:

Function	SINE WAVE (~)
Frequency	1 kHz
Amplitude	1 mVrms
Phase	0 Degrees
dc Offset	0V
Modulation	OFF
Sweep	OFF

3. Press the HP 3563A keys as follows:

[Control]			
PRESET	RESET	
[Input Setup]			
CAL	SINGLE CAL	
[Measurement]			
AVG	16 ENTER
	STABLE	
[Measurement]			
WINDOW	FLAT TOP	
[Display]			
A&B			
[Display]			
UNITS	P SPEC UNITS VOLTS RMS
[Input Setup]			
RANGE	AUTO 1 UP&DWN AUTO 2 UP&DWN

Table 3-4. Common Mode Rejection

Signal Amplitude	Signal Frequency	Specification
3.536 Vrms	66 Hz	≥ 80 dB
3.536 Vrms	500 Hz	≥ 65 dB

4. For each of the frequencies listed in Table 3-4 perform steps a through h:

a. Set the Frequency Synthesizer as follows:

Amplitude To signal amplitude in Table 3-4.
 Frequency To signal frequency in Table 3-4.

b. Press the HP 3563A keys as follows:

[Measurement]
FREQ CENTER To signal frequency in Table 3-4.
 FREQ

[Control]
START

[Markers]
SPCL
MARKER MRKR →
 PEAK

- c. Record the Ya marker amplitude reading on the Operation Verification Test Record as the first measurement for Channel 1.
- d. Record the Yb marker amplitude reading on the Operation Verification Test Record as the first measurement for Channel 2.
- e. Connect the test instruments as shown in Figure 3-8. If you do not have a common mode cable, use the alternate setup, Figure 3-9.

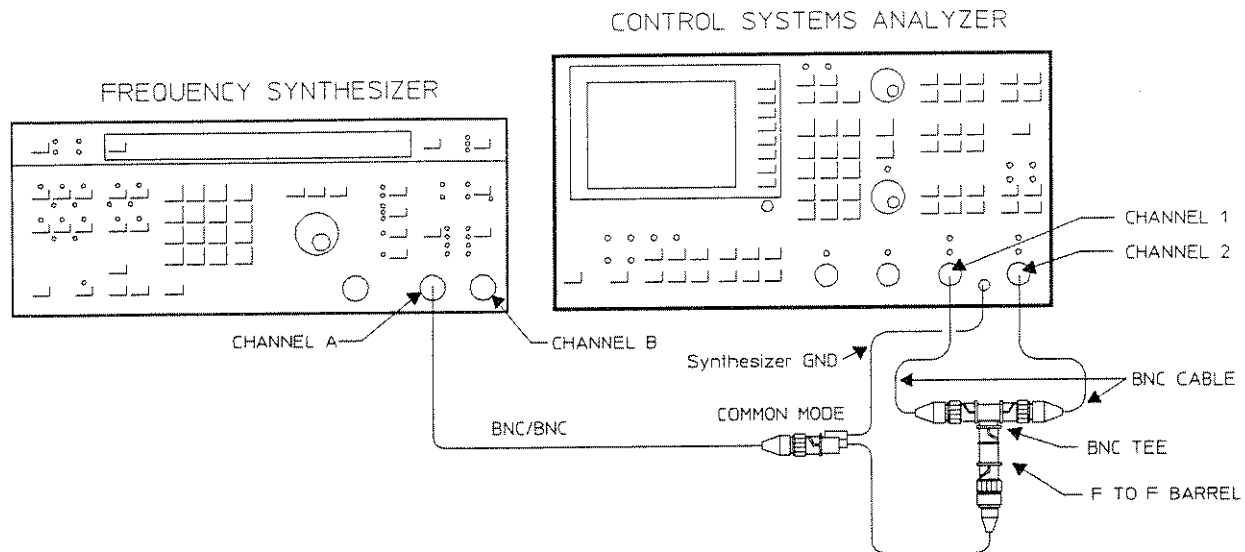

Figure 3-8. Common Mode Rejection Setup #2

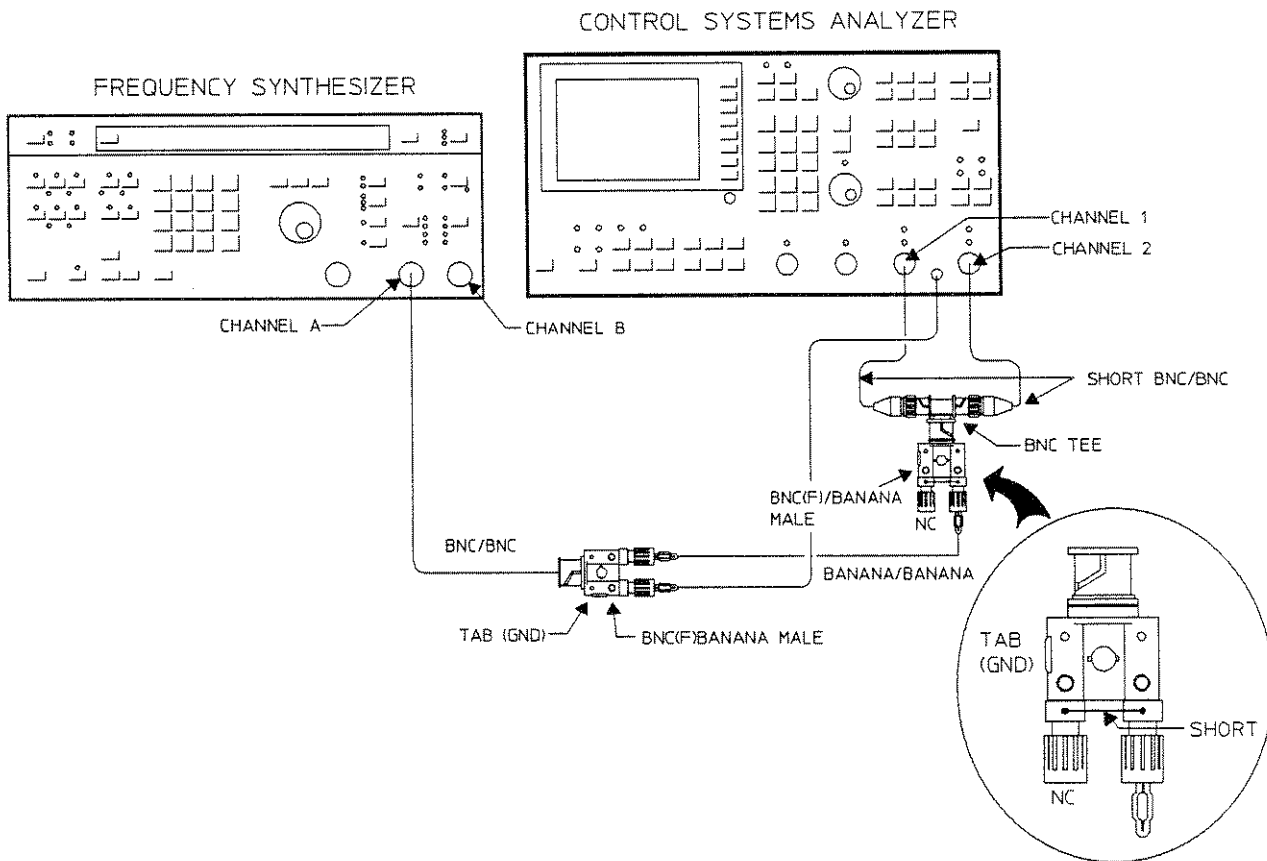

Figure 3-9. Alternate Common Mode Rejection Setup #2

Operation Verification Tests
6. Common Mode Rejection

f. Press the HP 3563A keys as follows:

[Control]
START

[Display]
SCALE Y AUTO
SCALE

[Markers]
X To signal frequency in Table 3-4.

g. When the average is complete, the message "Measurement Complete" appears in the lower right hand corner of the display. Record the Ya amplitude reading on the Operation Verification Test Record as the second measurement for Channel 1.

h. Record the Yb amplitude reading on the Operation Verification Test Record as the second measurement for Channel 2.

5. Calculate the relative value for both channels:

$$\text{First Measurement} - \text{Second Measurement} = \text{Relative Value}$$

If Test Fails

If this test fails, contact your local Hewlett-Packard sales and service office or have a qualified service technician see the following sections in the *HP 3563A Service Manual*:

Adjustments
Section III

Input dc Offset Adjustment
Calibrator Adjustment

Troubleshooting
Section VII

A33, A35 Input Boards
A30 Analog Source

7. Single Channel Phase Accuracy

This test measures the phase accuracy of the HP 3563A relative to the phase of the trigger signal. The frequency synthesizer is used to input a square wave to one channel and the external trigger input.

Required Test Equipment

- Frequency Synthesizer
- Female to Female Barrel
- 50Ω feedthrough termination
- BNC to BNC: length ≤ 30 cm (2)
- BNC Tees (2)
- BNC to BNC Cable (2)

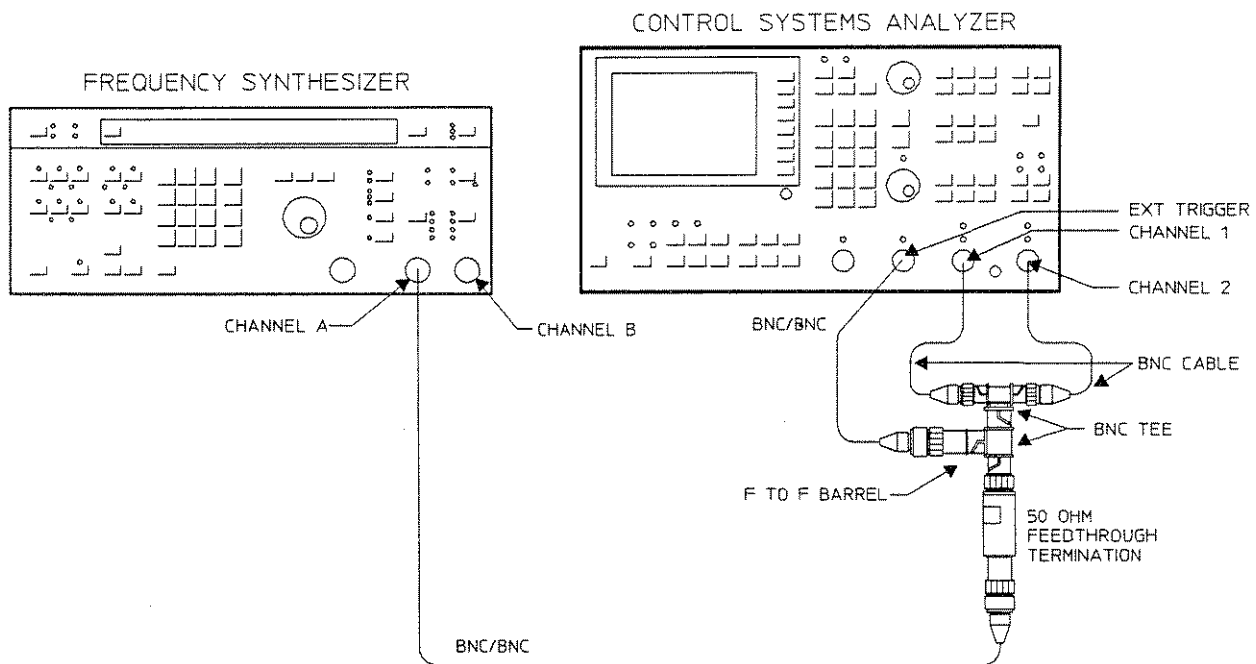

Figure 3-10. Single Channel Phase Accuracy

Procedure

1. Connect the test instruments as shown in Figure 3-10.
2. Set the test instrument initially as follows:

Frequency Synthesizer

Function	SQUARE WAVE (~)
Frequency	9 kHz
Amplitude	1 Vrms
Phase	0 Degrees
dc Offset	0 V dc
Modulation	OFF
Sweep	Off

3. Press the HP 3563A keys as follows:

[Control]		
PRESET	RESET
[Input Setup]		
CAL	SINGLE CAL
[Measurement]		
SELECT		
MEAS	POWER SPEC
[Measurement]		
AVG		
[Entry]		
5	ENTER
	STABLE
	TIM AV ON
[Measurement]		
WINDOW	UNIFRM (NONE)

```

[ Input Setup ]
  SELECT
  TRIG

[ Entry ]
  0      .....  V      .....  MORE
                                     TYPES

                                     .....  EXT
                                     TRIG

[ Display ]
  MEAS
  DISP   .....  FILTRD      .....  LINEAR
                                     INPUT      SPEC 1

[ Display ]
  B      .....  LINEAR
                                     SPEC 2

[ Display ]
  A&B

[ Display ]
  COORD  .....  PHASE

[ Control ]
  START

[ Markers ]
  X

[ Entry ]
  9      .....  kHz
  
```

4. Record the Ya marker reading on the Operational Verification Test Record for Channel 1.
5. Record the Yb marker reading on the Operational Verification Test Record for Channel 2.
6. Change the frequency of the frequency synthesizer to **99 kHz**.

Operation Verification Tests

7. Single Channel Phase Accuracy

7. Press the HP 3563A keys as follows:

[Input Setup]
SELECT
TRIG CHAN 1
 INPUT

[Control]
START

[Markers]
X

[Entry]
99 kHz

8. Record the Ya marker reading on the Operational Verification Test Record for Channel 1.

9. Record the Yb marker reading on the Operational Verification Test Record for Channel 2.

If Test Fails

If this test fails, contact your local Hewlett-Packard sales and service office or have a qualified service technician see the following sections in the *HP 3563A Service Manual*:

Adjustments	None
Troubleshooting Section VII	A33, A35 Input Boards A32, A34 Analog Digital Converter Boards A31 Trigger Board A6 Digital Filter Controller A1 Digital Source

8. Noise and Spurious Signal Level

This test measures the level of the noise floor and any spurious signals generated within the HP 3563A.

Required Test Equipment

- (2) 50Ω feedthrough terminations
- Alligator Clip Cables (2)

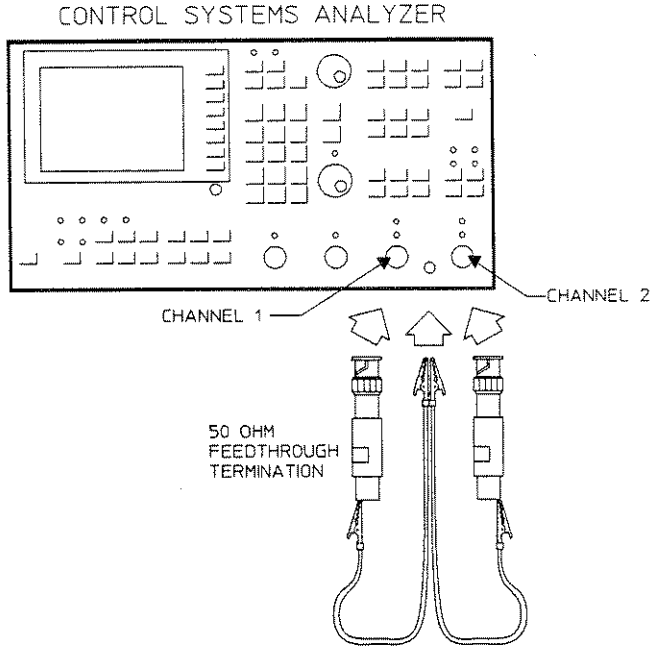

Figure 3-11. Noise and Spurious Signal Level Setup

Procedure

1. Connect the test instruments as shown in Figure 3-11. Keep the leads from the feedthrough terminations to chassis ground as short as possible.
2. Press the HP 3563A keys as follows:

[Control]
PRESET RESET

[Input Setup]
CAL SINGLE
CAL

Operation Verification Tests
 8. Noise and Spurious Signal Level

[Input Setup]
RANGE

[Entry]
 -51 dBVrms

[Input Setup]
INPUT CONFIG CHAN 1
 AC
 CHAN 2
 AC

[Measurement]
FREQ FREQ
 SPAN

[Entry]
 1 kHz START
 FREQ

[Entry]
 20 Hz

[Measurement]
AVG

[Entry]
 20 ENTER
 STABLE

[Measurement]
WINDOW UNIFRM
 (NONE)

[Display]
UNITS P SPEC
 UNITS VOLTS
 RMS
 VOLTS

3. Press the HP 3563A keys as follows:

[Control]
START

[Display]
SCALE Y AUTO
SCALE

[Markers]
SPCL
MARKER MRKR →
PEAK

4. If the Ya marker reading is less than or equal to -131 dBVrms check PASS on the Operation Verification Test Record for Channel 1.

5. Press the HP 3563A keys as follows:

[Display]
B

[Display]
SCALE Y AUTO
SCALE

[Markers]
SPCL
MARKER MRKR →
PEAK

6. If the Yb marker reading is less than or equal to -131 dBVrms check PASS on the Operation Verification Test Record for Channel 2.

Table 3-5. Spurious Signals

Start Frequency	Frequency Span	Specification
20Hz	1kHz	- 131dBV
1kHz	10kHz	- 131dBV
90kHz	10kHz	- 131dBV

7. Perform steps a through d for the start frequencies in Table 3-5:

a. Press the HP 3563A keys as follows:

[Measurement]
FREQ **START FREQ** To start frequency in Table 3-5.

[Display]
A **FREQ SPAN** To frequency span in Table 3-5.

[Control]
START

[Markers]
SPCL MARKER **MRKR → PEAK**

b. If the Ya marker reading is less than or equal to - 131 dBVrms check PASS on the Operation Verification Test Record for Channel 1.

c. Press the HP 3563A keys as follows:

[Display]
B

[Markers]
SPCL MARKER **MRKR → PEAK**

d. If the Yb marker reading is less than or equal to - 131 dBVrms check PASS on the Operation Verification Test Record for Channel 2.

8. Repeat steps 7a through 7d for the remaining start frequencies in Table 3-5.

9. Press the HP 3563A keys as follows:

```
[ Measurement ]
  WINDOW ..... FLAT
                        TOP

[ Display ]
  UNITS ..... P SPEC ..... V/√Hz
                        UNITS (√ PSD)
```

10. Perform steps a through e for each of the start frequencies listed in Table 3-6:

a. Press the HP 3563A keys as follows:

Table 3-6. Noise Level

Start Frequency	Frequency Span	Specification
20 Hz	1 kHz	$\leq -134\sqrt{\text{Hz}}$
1 kHz	50 kHz	$\leq -144\sqrt{\text{Hz}}$
50 kHz	50 kHz	$\leq -144\sqrt{\text{Hz}}$

```
[ Measurement ]
  FREQ ..... START To start frequency in Table 3-6.
                        FREQ

                        ..... FREQ To frequency span in Table 3-6.
                        SPAN

[ Control ]
  START
```

Operation Verification Tests
8. Noise and Spurious Signal Level

b. When the average is complete, press the HP 3563A keys as follows:

[Display]
A

[Markers]
SPCL
MARKER MRKR →
PEAK

c. If the Ya marker reading is less than or equal to the specification, check PASS on the Operation Verification Test Record for Channel 1.

d. Press the HP 3563A keys as follows:

[Display]
B

[Markers]
SPCL
MARKER MRKR →
PEAK

e. If the Yb marker reading is less than or equal to the specification, check PASS on the Operation Verification Test Record for Channel 2.

11. Repeat steps 10a through 10e for the remaining start frequencies in Table 3-6.

If Test Fails

If this test fails, contact your local Hewlett-Packard sales and service office or have a qualified service technician see the following sections in the *HP 3563A Service Manual*:

Adjustments
Section III

2nd Pass Gain Adjustment
ADC Offset and Reference Adjustment

Troubleshooting
Section VII

A33, A35 Input Boards
A32, A34 Analog Digital Converter
A5 Digital Filter
A4 Local Oscillator

9. Source Amplitude Accuracy and Flatness

This test measures the amplitude accuracy and flatness of the HP 3563A Source.

Required Test Equipment

BNC Cable

Procedure

1. Connect the HP 3563A Source to Channel 1.
2. Press the HP 3563A keys as follows:

[Control]			
PRESET	RESET	
[Input Setup]			
CAL	SINGLE	
		CAL	
[Input Setup]			
INPUT			
CONFIG	GROUND	
	CHAN 1	
[Input Setup]			
RANGE			
[Entry]			
5	V	
[Measurement]			
MEAS			
MODE	SWEPT	
		SINE
			LINEAR
			SWEEP
[Measurement]			
SOURCE	SOURCE	
		LEVEL	
[Entry]			
4.47	V	

Operation Verification Tests

9. Source Amplitude Accuracy and Flatness

[Display]
UNITS P SPEC VOLTS
UNITS RMS
..... VOLTS

[Measurement]
FREQ STOP
FREQ

[Entry]
65 kHz

[Control]
START

3. The sweep is done when the message, Measurement Complete, appears in the lower right hand corner of the display. Press the HP 3563A keys as follows:

[Display]
SCALE Y FIXD
SCALE

[Entry]
9,11 dB

4. If the trace is between the 9 dB and the 11 dB limits, check PASS on the Operation Verification Test Record for the 0 to 65 kHz span.

5. Press the HP 3563A keys as follows:

[Measurement]
FREQ START
FREQ

[Entry]
65 kHz

[Control]
START

6. When the sweep is done, press the HP 3563A keys as follows:

[Display]
SCALE Y FIXD
SCALE

[Entry]
8.5, 11 dB

7. If the trace is between the 8.5 dB and the 11 dB limits, check PASS on the Operation Verification Test Record for the 65 kHz to 100 kHz span.

If Test Fails

If this test fails, contact your local Hewlett-Packard sales and service office or have a qualified service technician see the following sections in the *HP 3563A Service Manual*:

Adjustments

None

Troubleshooting
Section VIII

A30 Analog Source Board

Operational Verification Test Record

HP 3563 A
Control Systems Analyzer

Tested by: _____

Serial No. _____ Location: _____

Customer Name _____ Repair Order No. _____

Temperature Range _____ Date: _____

Relative Humidity _____

Instruments Used:

AC Calibrator _____ Model _____
Serial No. _____

Frequency Synthesizer _____ Model _____
Serial No. _____

Digital Voltmeter _____ Model _____
Serial No. _____

Other _____

Other _____

This Test Record Form may be reproduced without written permission of Hewlett-Packard

1. Self Test	PASS
---------------------	-------------

2. DC Offset			
Range Setting	Measured Value		Specification
	CHANNEL 1	CHANNEL 2	
-51 dBV			<-71 dBV

3. Amplitude Accuracy and Flatness					
CHANNEL 1 and CHANNEL 2 Floating					
Range Setting	Signal Frequency	Specification		Measured Value	
		Lower Limit	Upper Limit	CHANNEL 1	CHANNEL 2
9 dBV	1 kHz	8.849 dBV	9.151 dBV		
9 dBV	99 kHz	8.849 dBV	9.151 dBV		
0 dBV	1 kHz	-0.1513 dBV	0.1513 dBV		
0 dBV	99 kHz	-0.1513 dBV	0.1513 dBV		
-13 dBV	1 kHz	-1315 dBV	-12.85 dBV		
-13 dBV	99 kHz	-1315 dBV	-12.85 dBV		

4. Amplitude and Phase Match .						
Range Setting	Part	PASS	Amplitude Specification	Part	PASS	Phase Specification
- 49 dBV	1		± 0.1 dB	4		± 0.5°
- 0 dBV	2		± 0.1 dB	5		± 0.5°
- 10 dBV	3		± 0.1 dB	6		± 0.8°

5. Frequency Accuracy			
Signal Frequency	Specification		Measured Value
	Lower Limit	Upper Limit	
99,000 Hz	98.996 kHz	99.004 kHz	

6. Common Mode Rejection				
		First Measurement – Second Measurement = Relative Value		
Signal Frequency	CHANNEL 1			Specification
	First Measurement	Second Measurement	Relative Value	
66 Hz				≥ 80 dB
500 Hz				≥ 65 dB
Signal Frequency	CHANNEL 2			Specification
	First Measurement	Second Measurement	Relative Value	
66 Hz				≥ 80 dB
500 Hz				≥ 65 dB

7. Single Channel Phase Accuracy						
Signal Frequency	Trigger		Specification		Measured Value	
	Slope	Type	Lower Limit	Upper Limit	CHAN 1	CHAN 2
9 kHz	POS	EXT	– 92.5°	– 87.5°		
99 kHz	POS	CHAN 1	– 102°	– 78.0°		

8. Noise and Spurious Signal Level				
Spurious Signals				
Start Frequency	Frequency Span	PASS		Specification
		CHAN 1	CHAN 2	
20 Hz	1 kHz			≤ – 131 dBV
1 kHz	10 kHz			≤ – 131 dBV
90 kHz	10 kHz			≤ – 131 dBV
Noise Level				
Start Frequency	Frequency Span	PASS		Specification
		CHAN 1	CHAN 2	
20 kHz	1 kHz			≤ – 134 dBV/√Hz
1 kHz	50 kHz			≤ – 144 dBV/√Hz
50 kHz	50 kHz			≤ – 144 dBV/√Hz

9. Source Amplitude Accuracy and Flatness	
0 Hz to 65 kHz	PASS
65 kHz to 100 kHz	PASS

Performance Tests

Introduction

This chapter contains performance tests for the HP 3563A. These tests provide the highest level of confidence that the instrument is operating properly and verify that the HP 3563A is meeting its published specifications. Use the “Operational Verification,” Chapter 3, for incoming and after-repair inspections.

Test Duration

The performance tests take approximately eight hours to complete.

Caution



Before applying line power to the analyzer or testing its electrical performance, see Chapter 5, “Installation.”

Calibration Cycle

To verify the HP 3563A is operating within specifications, perform the performance tests every 12 months.

Tested Specifications

The following table list all the specifications and the corresponding performance tests.

Table 4-1. Specifications Versus Performance Tests

Specification	Performance Tests
Cross Talk Phase Accuracy	Single Channel Phase Accuracy
Digital Reading	Digital I/O
Input Impedance	Input Impedance
Dynamic Range	Anti-Alias Filter Response Harmonic Distortion Intermodulation Distortion
Noise Floor	Noise and Spurious Signal Level
Cross Talk	Cross Talk
Common Signal Rejection	Common Mode Rejection
External Reference Input	External Reference Test
Source dc Offset	Source Residual Offset
Source Accuracy and Purity	Source Amplitude Accuracy and Flatness
Source Distortion	Source Distortion
Source Noise	Source Energy Measurement

Recommended Test Equipment

The equipment needed to perform the HP 3563A performance tests is listed in Table 4-2. Other equipment may be substituted for the recommended model if it meets or exceeds the listed critical specifications. Instruments meeting or exceeding the critical specifications will provide a 4 to 1 (or better) test accuracy ratio for each characteristic calibrated in the performance test procedures. You may have to modify the procedures to accommodate the different operating characteristics if substitutions are made.

Resistance	Tolerance	Power	HP Part Number
1 k Ω	1%	0.25 W	0757-0280
100 k Ω	1%	0.25 W	0757-0465

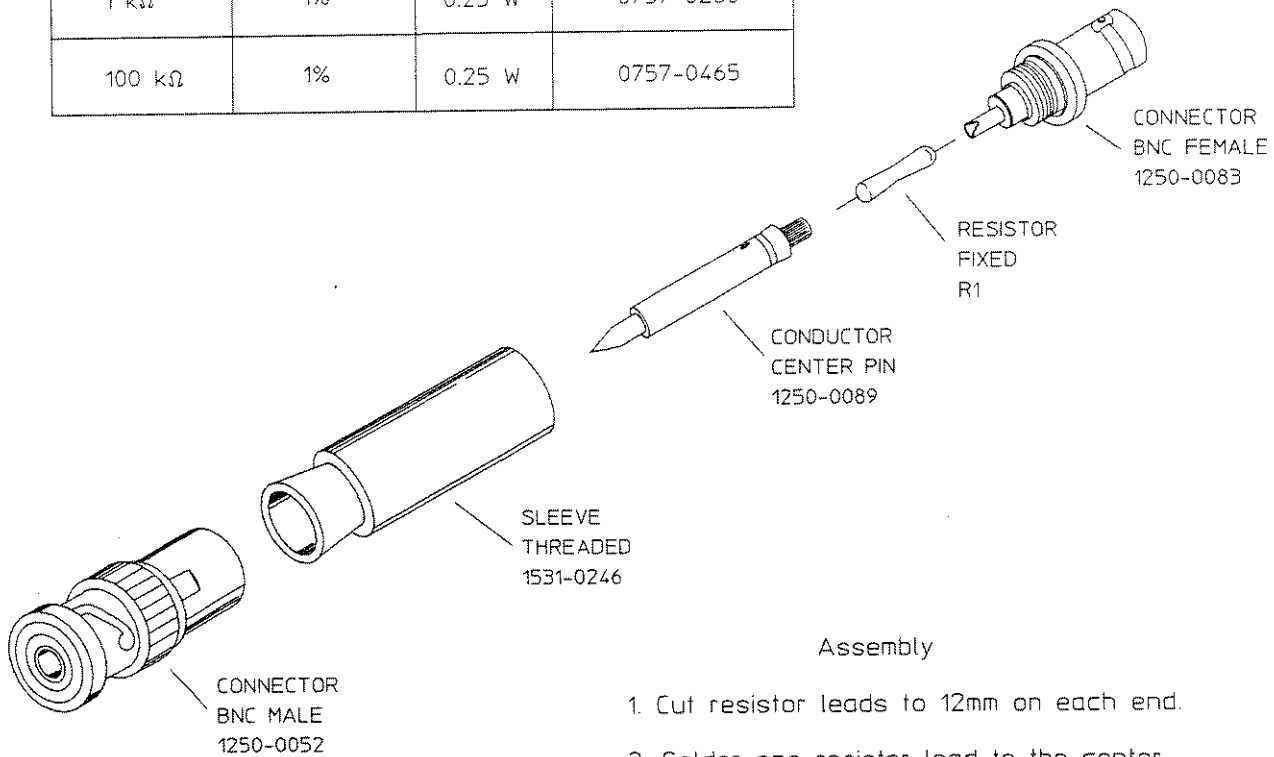

Assembly

1. Cut resistor leads to 12mm on each end.
2. Solder one resistor lead to the center conductor of the BNC FEMALE connector.
3. Solder the CONDUCTOR CENTER PIN to the other lead of the resistor.
4. Screw the SLEEVE and the BNC MALE connector into place. Tighten securely.

Figure 4-1. Constructing Feedthrough

Table 4-2. Recommended Test Equipment

Instrument	Critical Specifications	Recommended Model
AC Calibrator	10 Hz to 100 kHz; 1 mV to 10V Amplitude Accuracy: $\pm .1\%$ Phase Locking Capability	Fluke 5200A Alternative: HP 745A Datron 4200
Two Channel Frequency Synthesizer	Frequency Range: 10 Hz to 1 MHz Frequency Accuracy: 10 ppm Synthesizer Amplitude Range: 40 Vp-p Amplitude Accuracy: ≤ 0.2 dB from 1 Hz to 100 kHz 1 dB from 100 kHz to 1 MHz Dynamic Range: ≤ -80 dBc, 10 Hz to 100 kHz	HP 3326A Opt 002 Alternative:* (2) HP 3325A/B Opt 001 Opt 002
Digital Voltmeter	5 1/2 digit, Math: Mean AC Voltage: 30 Hz to 100 kHz; 0.1 to 500V; $\pm 0.1\%$; ≥ 1 M Ω input impedance dc Voltage: 1V to 300V; $\pm 0.1\%$	HP 3456A
Low Distortion Oscillator	Frequency Range: 1 Hz to 100 kHz Amplitude Range: 0.1 V to 1 Vrms Distortion: ≤ -80 dB (0.01%)	HP 339A Alternative: HP 3326A
Feedthrough Terminations	(2) 50 Ω : $\pm 2\%$ at dc (2) 600 Ω : $\pm 2\%$ at dc	HP 11048C Alternative: Pomona Elect. Model 4119-50 HP 10100C HP 11095A Alternative: Pomona Elect. Model 4119-600
Cables	(2) BNC to BNC: length ≤ 30 cm (2) BNC/BNC Cable 122 cm (1) BNC/Dual Banana (2) Single Banana/Single Banana Common Mode Cable Test Board (3) 8-bit output probe cables (3) 16-bit input probe cable	HP 8120-1838 HP 8120-1840 HP 11001-60001 Pomona Elect. Model 2948-24-0 HP 03562-61620 HP 03563-66540 HP 03563-61604 HP 01650-61607

* May not meet MIL 45662A

** No specific model number is recommended, any variable AC power supply which meets the listed critical specifications may be used.

Table 4-2. Recommended Test Equipment (cont'd)

Instrument	Critical Specifications	Recommended Model
Clips	(2) Alligator Clip	Pomona Elect. Model 1613-8-0
Adapters	(1) BNC (m) to Dual Banana (f) (2) BNC (f) to Dual Banana (m) (2) BNC Tee (m)(f)(f) (1) BNC (f) to BNC (f)	Pomona Elect. Model 1296 HP 1251-2277 HP 1250-0781 HP 1250-0080
Resistors	(2) Value: 100 k Ω Accuracy: 1% Power: 0.25W (1) Value: 1 k Ω Accuracy: 1% Power: 0.25W	HP 0757-0280 (See Figure 4-1) HP 0757-0465 (See Figure 4-1)
Test Board OR Cables	No Substitute (3) 16-bit Input Probe Pod (3) 16-bit Pattern Generator (4) Grabbers (Package of 20)	HP 03563-66540 HP 03563-61605 HP 10347A HP 5959-0288

* May not meet MIL 45662A

** No specific model number is recommended, any variable AC power supply which meets the listed critical specifications may be used.

Initial Equipment Setup

When the recommended test equipment of Table 4-2 is used to complete the performance tests, the instruments below must be set to the preset conditions listed, before beginning a test. In each test, any unspecified parameters should be set to the following conditions:

Frequency Synthesizer (Both Channels)

Function	SINE WAVE (~)
High Voltage Output	OFF
Amplitude	1 mVrms
Phase	0 Degrees
dc Offset	0V
Modulation	OFF
Sweep	OFF

AC Calibrator

Frequency	1 kHz
Amplitude01 Vrms
Voltage Error %	OFF
Vernier	0
Mode	OPER
Control	LOCAL
Phase Lock	OFF
Sense	INTERNAL

Digital Voltmeter

Function	ac V (~V)
Range	AUTO
Trigger	INTERNAL
Sample Rate	MAXIMUM
High Resolution	ON
Auto Cal	ON

How To Perform A Performance Test

Conventions

There are two types of keys on the HP 3563A, hardkeys and softkeys. Hardkeys are organized on the front panel according to functional group. See Figure 4-2. In these procedures, the functional group is in brackets, the hardkey appear in bold text and the softkeys are in regular text.

The following example sets a frequency span of 10 kHz. You first press the hardkey **FREQ** which is found in the Measurement group, followed by the softkey **FREQ SPAN**. Next, enter the number 10 on the numeric keypad located in the Entry group. Specify the measurement unit by pressing the kHz softkey.

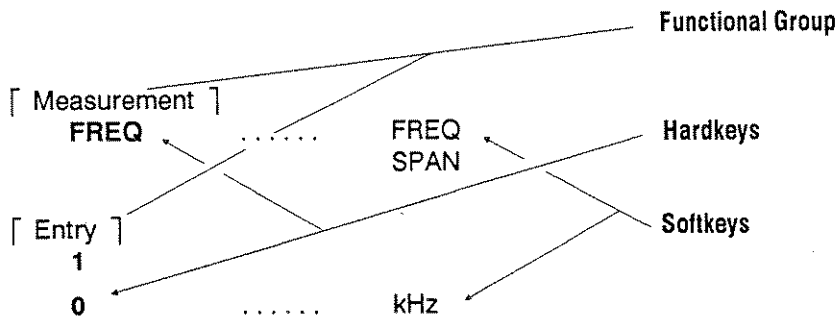

Note



In the following test procedures, numeric values may require multiple keystrokes. In the previous example, the value 10 requires two keystrokes, 1 and 0. In the procedures, these keystrokes are represented as 10.

If you make an incorrect keystroke, press the previous hardkey. This will return you to a first level menu which allows you to continue with the procedure.

All test must be performed with Automatic Calibration **ON**. When the instrument powers up, Auto Cal is on, **do not turn it off**.

Performance Tests
 How To Perform A Performance Test

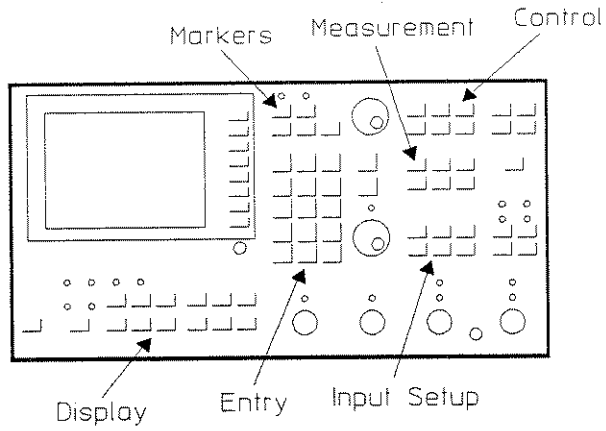

Figure 4-2. HP 3563A Front View - Functional Groups

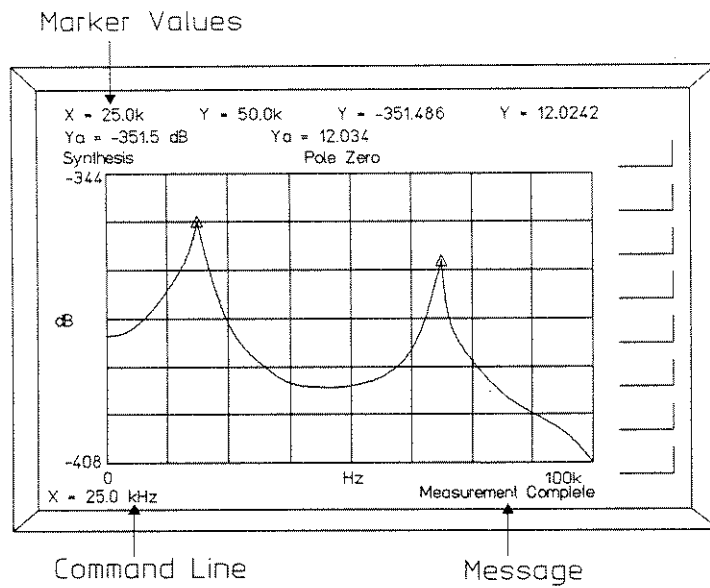

Figure 4-3. HP 3563A Display

Procedure

1. Start each performance test by setting the test equipment to the specified conditions .
If no conditions are listed, set the test equipment to those listed in the preceding section, Initial Setup.
2. Enter the keys specified in the procedure.
3. Record the position of the X and Y markers as indicated for each test. Refer to Figure 4-3 for an example of the position of the X and Y marker readings. Additional information about reading the X and Y marker positions is available in the *HP 3563A Operating Reference Manual*.
4. Record the results of each of the performance tests on the "Performance Test Record," located at the end of this chapter. **This test record may be reproduced without written permission of Hewlett-Packard.**
5. If the HP 3563A fails a test, see the "If Test Fails" section at the end of each test.

Note



The instrument will not record any keystroke during a calibration cycle or a measurement. A status message appears in the lower-right corner of the display. See Figure 4-3.

Note



To minimize the time required to change instrument configurations between tests, do the tests in the order given.

1. Self Test

This test determines if the HP 3563A is operating correctly. No tests should be attempted until the instrument passes this test.

Required Test Equipment

None

Test Duration

This test takes about 1 minute to complete.

Procedure

1. Press the HP 3563A keys as follows:

[Control]					
SPCL					
FCTN	SELF	SELF	
		TEST		TEST	

2. During the Self Test cycle, the message "Diagnostic In Progress" will appear in the message area. Keystrokes are not recorded during calibration and measurements. You must wait until the measurement is completed.
3. When "Self Test Passes" is displayed in the lower right corner of the display, check PASS on the Operational Verification Test Record.

If Test Fails

If this test fails, contact your local Hewlett-Packard sales and service office or have a qualified service technician see the following sections in the *HP 3563A Service Manual*:

"Fault Isolation Section", Section VII.

2. DC Offset

This test measures the level of the dc offset generated within the HP 3563A with Auto Cal on.

Specification

For range settings between +27 dBV and -35 dBV the dc offset will be greater than 30 dB below the range setting. For range settings between -36 dBV and -51 dBV the offset will be greater than 20 dB below the range setting.

Required Test Equipment

- 50Ω feedthrough terminations (2)
- Alligator Clip Cables (2)

Table 4-3. DC Offset

Range Setting	Specification
7 dBVrms	< -23 dBV
-35 dBVrms	< -65 dBV
-51 dBVrms	< -71 dBV

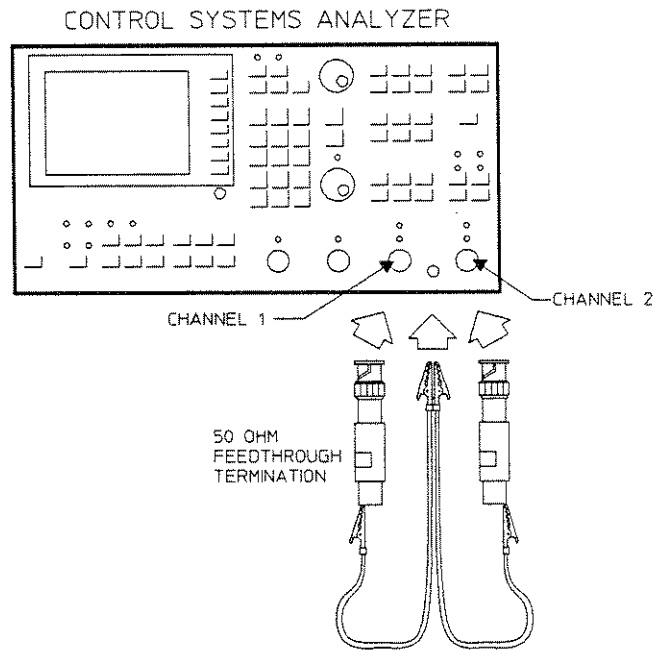

Figure 4-4. DC Offset Test Setup

Performance Tests

2. DC Offset

Procedure

1. Connect the HP 3563A as shown in Figure 4-4. Keep the leads to chassis ground as short as possible.
2. Press the HP 3563A keys as follows:

[Control]				
PRESET	RESET		
[Input Setup]				
CAL	AUTO		
		ON		
	SINGLE		
		CAL		
[Measurement]				
WINDOW	UNIFRM		
		(NONE)		
[Measurement]		[Entry]		
AVG	2	ENTER
	STABLE		
[Measurement]		[Entry]		
FREQ	1	kHz
[Display]				
UNITS	P SPEC	VOLTS
		UNITS		RMS
			VOLTS
[Display]				
A&B				
[Markers]		[Entry]		
X	0	Hz

3. For each of the range settings listed in Table 4-3, perform steps a through c:

a. Press the HP 3563A keys as follows:

[Input Setup]
 RANGE To range setting in Table 4-3.

[Control]
 START

b. Record the Ya marker reading on the Performance Test Record for the Channel 1 measured value.

c. Record the Yb marker reading on the Performance Test Record for the Channel 2 measured value.

If Test Fails

If this test fails, contact your local Hewlett-Packard sales and service office or have a qualified service technician see the following sections in the *HP 3563A Service Manual*:

Adjustments
Section III

Track and Hold Offset Adjustment
Input DC Offset Adjustment

Troubleshooting
Section VIII

A33, A35 Input Boards
A32, A34 Analog Digital Converter Boards

3. Amplitude Accuracy and Flatness

This test measures the amplitude accuracy and flatness of the HP 3563A using the amplitude reference of the ac calibrator.

Specification

If the measurement of a signal is between the BNC center conductor and BNC shell and the amplitude is equal to the range setting, the marker amplitude reading will not deviate from the actual signal amplitude by more than:

Range Setting	Accuracy
+27 dBV to -40 dBV	$\pm 0.15 \text{ dB} \pm 0.015\% \text{ Range Setting}$
-41 dBV to -51 dBV	$\pm 0.25 \text{ dB} \pm 0.025\% \text{ Range Setting}$

If the measurement of a signal includes a signal between the BNC shell and the chassis, the marker amplitude reading will not deviate from the actual signal amplitude by more than:

Range Setting	Accuracy
+27 dBV to -40 dBV	$\pm 0.50 \text{ dB} \pm 0.015\% \text{ Range Setting}$
-41 dBV to -51 dBV	$\pm 0.60 \text{ dB} \pm 0.025\% \text{ Range Setting}$

Required Test Equipment

Frequency Synthesizer
 BNC Cable (3)
 AC Calibrator
 Single Banana to Single Banana
 Female to Female Barrel
 BNC to Dual Banana
 BNC Tee (m)(f)(f)

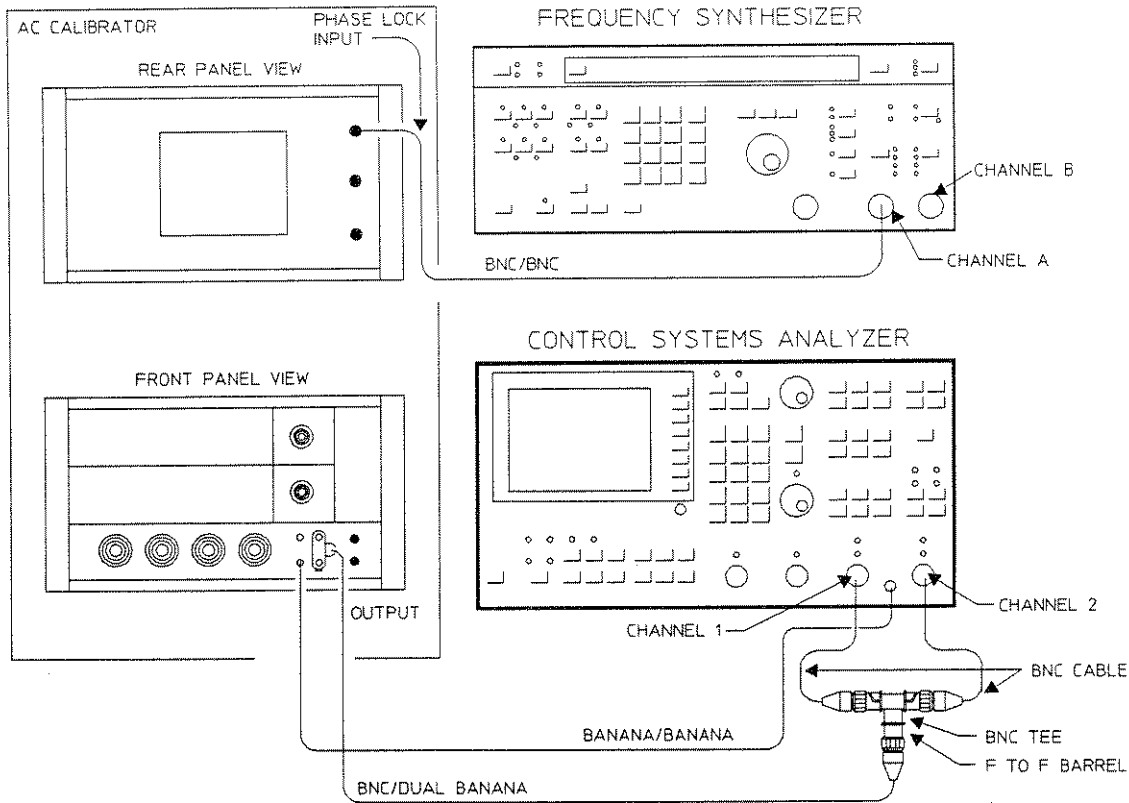

Figure 4-5. Amplitude Accuracy and Flatness Test Setup

Procedure

1. Connect the test instruments as shown in Figure 4-5.
2. Set the test instruments initially as follows:

Frequency Synthesizer

Function	SINE WAVE (~)
Frequency	1 kHz
Amplitude	0.5 Vrms
Phase	0 Degrees
dc Offset	0V
Modulation	OFF
Sweep	OFF

Performance Tests
 3. Amplitude Accuracy and Flatness

AC Calibrator

Frequency	1 kHz
Amplitude	2.8184 Vrms
Voltage		
Error %	OFF
Vernier	0
Mode	OPER
Control	LOCAL
Phase Lock	ON
Sense	INTERNAL

3. Press the HP 3563A keys as follows:

[Control]			
PRESET	RESET	
[Input Setup]			
CAL	SINGLE	
		CAL	
[Input Setup]			
INPUT			
CONFIG	GROUND	
		CHAN 1	
	GROUND	
		CHAN 2	
[Measurement]			
WINDOW	FLAT	
		TOP	
[Measurement]		[Entry]	
AVG	4 ENTER
	STABLE	
[Display]			
UNITS	P SPEC VOLTS
		UNITS	RMS
		 VOLTS
[Display]			
A & B			

Amplitude Accuracy and Flatness Measurement One

Table 4-4. Amplitude Accuracy and Flatness
Measurement One

BNC shell grounded				
HP 3563A Range	Signal Frequency	AC Calibrator Amplitude	Specification	
			Lower Limit	Upper Limit
9 dBVrms	1 kHz	2.8184 Vrms	8.849 dBV	9.151 dBV
9 dBVrms	99 kHz	2.8184 Vrms	8.849 dBV	9.151 dBV
-13 dBVrms	1 kHz	.22387 Vrms	-13.15 dBV	-12.85 dBV
-13 dBVrms	50 kHz	.22387 Vrms	-13.15 dBV	-12.85 dBV
-13 dBVrms	90 kHz	.22387 Vrms	-13.15 dBV	-12.85 dBV
-13 dBVrms	99 kHz	.22387 Vrms	-13.15 dBV	-12.85 dBV
-23 dBVrms	1 kHz	70.795 mVrms	-23.15 dBV	-22.85 dBV
-23 dBVrms	99 kHz	70.795 mVrms	-23.15 dBV	-22.85 dBV
-26 dBVrms	1 kHz	50.119 mVrms	-26.15 dBV	-25.85 dBV
-21 dBVrms	1 kHz	89.125 mVrms	-21.15 dBV	-20.85 dBV
-17 dBVrms	1 kHz	.14125 Vrms	-17.15 dBV	-16.85 dBV
-14 dBVrms	1 kHz	.19953 Vrms	-14.15 dBV	-13.85 dBV
-11 dBVrms	1 kHz	.28184 Vrms	-11.15 dBV	-10.85 dBV

Procedure

1. Press the HP 3563A keys as follows:

[Input Setup]
RANGE To range setting in Table 4-4.

[Measurement]
FREQ **CENTER** To signal frequency
FREQ in Table 4-4.

2. Set the AC Calibrator to the signal frequency in Table 4-4.
3. Set the Frequency Synthesizer to the signal frequency in Table 4-4.
4. Set the AC Calibrator to the amplitude in Table 4-4.

Performance Tests

3. Amplitude Accuracy and Flatness

5. Press the HP 3563A keys as follows:

[Control]
START

[Markers]
SPCL
MARKER MRKR →
PEAK

6. Record the Ya marker reading on the Performance Test Record for the measured value Channel 1.
7. Record the Yb marker reading on the Performance Test Record for the measured value Channel 2.
8. Repeat steps 1 through 7 for each of the remaining settings in Table 4-4.

Amplitude Accuracy and Flatness Measurement Two

Table 4-5. Amplitude Accuracy and Flatness
 Measurement Two

BNC shell grounded				
HP 3563A Range	Signal Frequency	AC Calibrator Amplitude	Specification	
			Lower Limit	Upper Limit
-51 dBVrms	1 kHz	2.8184 mVrms	-51.25 dBV	-50.75 dBV
-49 dBVrms	1 kHz	3.5481 mVrms	-49.25 dBV	-48.75 dBV
-47 dBVrms	1 kHz	4.4668 mVrms	-47.25 dBV	-46.75 dBV
-45 dBVrms	1 kHz	5.6234 mVrms	-45.25 dBV	-44.75 dBV
-43 dBVrms	1 kHz	7.0795 mVrms	-43.25 dBV	-42.75 dBV
-41 dBVrms	1 kHz	8.9125 mVrms	-41.25 dBV	-40.75 dBV
-39 dBVrms	1 kHz	11.220 mVrms	-39.25 dBV	-38.75 dBV

Procedure

1. Press the HP 3563A keys as follows:

[Input Setup]
RANGE To range setting in Table 4-5.

[Measurement]
FREQ **CENTER** To signal frequency
FREQ in Table 4-5.

2. Set the AC Calibrator to the signal frequency in Table 4-5.
3. Set the Frequency Synthesizer to the signal frequency in Table 4-5.
4. Set the AC Calibrator to the amplitude in Table 4-5.

Performance Tests

3. Amplitude Accuracy and Flatness

5. Press the HP 3563A keys as follows:

[Control]
START

[Markers]
SPCL
MARKER MRKR→
PEAK

6. Record the Ya marker reading on the Performance Test Record for the measured value Channel 1.
7. Record the Yb marker reading on the Performance Test Record for the measured value Channel 2.
8. Repeat steps 1 through 7 for each of the remaining settings in Table 4-5.

Amplitude Accuracy and Flatness Measurement Three

Table 4-6. Amplitude Accuracy and Flatness Measurement Three

BNC shell grounded				
HP 3563A Range	Signal Frequency	AC Calibrator Amplitude	Specification	
			Lower Limit	Upper Limit
8 dBVrms	1 kHz	2.5119 Vrms	7.499 dBV	8.501 dBV
8 dBVrms	99 kHz	2.5119 Vrms	7.499 dBV	8.501 dBV
-11 dBVrms	1 kHz	0.28184 Vrms	-11.50 dBV	-10.50 dBV
-13 dBVrms	1 kHz	0.22387 Vrms	-13.50 dBV	-12.50 dBV
-13 dBVrms	50 kHz	0.22387 Vrms	-13.50 dBV	-1250 dBV
-13 dBVrms	90 kHz	0.22387 Vrms	-13.50 dBV	-1250 dBV
-13 dBVrms	99 kHz	0.22387 Vrms	-13.50 dBV	-12.50 dBV
-27 dBVrms	1 kHz	44.668 mVrms	-27.50 dBV	-26.50 dBV
-27 dBVrms	99 kHz	44.668 mVrms	-27.50 dBV	-26.50 dBV

Procedure

1. Press the HP 3563A keys as follows:

```
[ Input Setup ]
  INPUT
  CONFIG      .....   FLOAT
                                     CHAN 1
                                     .....
                                     FLOAT
                                     CHAN 2
```

2. Reverse the banana plug connector at the ac calibrator so the high input signal goes to the BNC shell of HP 3563A's input channels. The BNC center conductor should be grounded for each channel.

3. Press the HP 3563A keys as follows:

```
[ Input Setup ]
  RANGE      .....   To range setting in Table 4-6

[ Measurement ]
  FREQ       .....   CENTER      .....   To signal frequency
                                     FREQ          in Table 4-6.
```

4. Set the AC Calibrator to the signal frequency in Table 4-6.
5. Set the Frequency Synthesizer to the signal frequency in Table 4-6.
6. Set the AC Calibrator to the amplitude in Table 4-6.

Performance Tests

3. Amplitude Accuracy and Flatness

7. Press the HP 3563A keys as follows:

[Control]
START

[Markers]
SPCL
MARKER MRKR→
PEAK

8. Record the Ya marker reading on the Performance Test Record for the measured value Channel 1.

9. Record the Yb marker reading on the Performance Test Record for the measured value Channel 2.

10. Repeat steps 3 through 9 for each of the remaining settings in Table 4-6.

If Test Fails

If this test fails, contact your local Hewlett-Packard sales and service office or have a qualified service technician see the following sections in the *HP 3563A Service Manual*:

Adjustments
Section III

2nd Pass Gain Adjustment
AC Offset and Reference Adjustment
Input Flatness Adjustment
Input Attenuator Adjustments
Calibrator Adjustment

Troubleshooting
Section VII

A33, A35 Input Boards
A32, A34 Analog Digital Converter Boards
A30 Analog Source Board

4. Amplitude Linearity

This test measures the amplitude linearity of the HP 3563A by using the amplitude reference of the AC Calibrator.

Specification

If the measurement of a signal is between the BNC center conductor and BNC shell and the amplitude is equal to the range setting, the marker amplitude reading will not deviate from the actual signal amplitude by more than:

Range Setting	Accuracy
+27 dBV to -40 dBV	$\pm 0.15 \text{ dB} \pm 0.015\% \text{ Range Setting}$
-41 dBV to -51 dBV	$\pm 0.25 \text{ dB} \pm 0.025\% \text{ Range Setting}$

If the measurement of a signal includes a signal between the BNC shell and the chassis, the marker amplitude reading will not deviate from the actual signal amplitude by more than:

Range Setting	Accuracy
+27 dBV to -40 dBV	$\pm 0.50 \text{ dB} \pm 0.015\% \text{ Range Setting}$
-41 dBV to -51 dBV	$\pm 0.60 \text{ dB} \pm 0.025\% \text{ Range Setting}$

Required Test Equipment

Frequency Synthesizer
 BNC Cable (3)
 AC Calibrator
 Single Banana to Single Banana
 Female to Female Barrel
 BNC to Dual Banana
 BNC Tee (m)(f)(f)

Performance Tests
 4. Amplitude Linearity

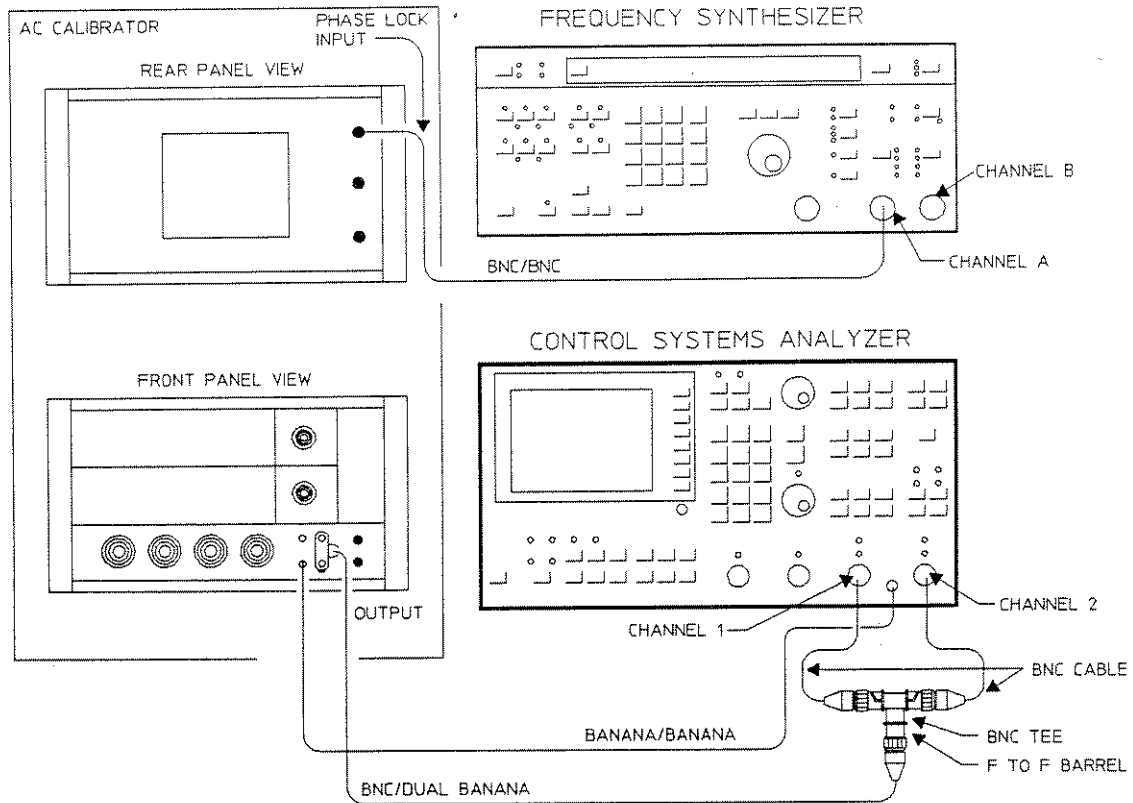

Figure 4-6. Amplitude Linearity Test Setup

Procedure

1. Connect the test instruments as shown in Figure 4-6.
2. Set the test instruments initially as follows:

Frequency Synthesizer

Function	SINE WAVE (~)
Frequency	10 kHz
Amplitude	1 Vrms
Phase	0 Degrees
dc Offset	0V
Modulation	OFF
Sweep	OFF

AC Calibrator

Frequency	10 kHz
Amplitude	10 Vrms
Voltage		
Error %	OFF
Vernier	0
Mode	OPER
Control	LOCAL
Phase Lock	ON
Sense	INTERNAL

3. Press the HP 3563A keys as follows:

[Control]			
PRESET	RESET	
[Input Setup]			
CAL	SINGLE CAL	
[Measurement]			
WINDOW	FLAT TOP	
[Measurement]		[Entry]	
AVG	4 ENTER
	STABLE	
[Input Setup]		[Entry]	
RANGE	21 dBVrms
[Measurement]			[Entry]
FREQ	CENTER FREQ 10 kHz
[Input Setup]			
INPUT CONFIG	GROUND CHAN 1	
	GROUND CHAN 2	

Performance Tests
4. Amplitude Linearity

```
[ Display ]
  UNITS      ..... P SPEC      ..... VOLTS
              RMS
              ..... VOLTS
```

```
[ Display ]
  A&B
```

Note



Y AUTO SCALE may not scale below 100 mV when on the 21 dBV RMS range; however, the measurement value is correct. The Y scale can be set manually by using Y FIXED SCALE.

```
[ Display ]
  COORD      ..... MAG
              (LIN)
```

```
[ Display ]
  SCALE      ..... Y AUTO
              SCALE
```

Table 4-7. Amplitude Linearity

AC Calibrator Amplitude	Specification BNC shell grounded		Specification BNC center conductor grounded	
	Upper Limit	Lower Limit	Upper Limit	Lower Limit
10.00 Vrms	10.18 Vrms	9.827 Vrms	10.59 Vrms	9.439 Vrms
1000 Vrms	1.019 Vrms	981.4 mVrms	1.061 Vrms	942.6 mVrms
100.0 mVrms	103.2 mVrms	96.79 mVrms	107.4 mVrms	92.91 mVrms
10.00 mVrms	11.67 mVrms	8.329 mVrms	12.09 mVrms	7.941 mVrms
3.1623 mVrms	4.717 mVrms	1.608 mVrms	4.850 mVrms	1.485 mVrms
1.000 mVrms	2.517 mVrms	- 517.1 μ Vrms	2.559 mVrms	- 555.9 μ Vrms

4. For each of the amplitudes listed in Table 4-9, perform steps a through d.
 - a. Set the AC Calibrator to the amplitude listed in Table 4-9.
 - b. Press the HP 3563A keys as follows:

```
[ Control ]
  START
```

```
[ Markers ]
  SPCL
  MARKER  ..... MRKR →
              PEAK
```

- c. Record the Ya marker reading on the Performance Test Record for the measured value Channel 1.
 - d. Record the Yb marker reading on the Performance Test Record for the measured value Channel 2.
5. Press the HP 3563A keys as follows:

```
[ Input Setup ]  
  INPUT  
  CONFIG      .....   FLOAT  
                                     CHAN 1  
                                     .....   FLOAT  
                                     CHAN 2
```

- 6. Reverse the banana plug connector at the ac calibrator so the high input signal goes to the BNC shell of HP 3563A's input channels. The BNC center conductor should be grounded for each channel.
- 7. Repeat 4a through 4d for BNC center conductor grounded.

If Test Fails

If this test fails, contact your local Hewlett-Packard sales and service office or have a qualified service technician see the following sections in the *HP 3563A Service Manual*:

Adjustments
Section III

2nd Pass Gain Adjustment
ADC Offset and Reference Adjustment
Input Flatness Adjustment
Input Attenuator Adjustments
Calibrator Adjustment

Troubleshooting
Section VII

A33, A35 Input Boards
A32, A34 Analog Digital Converter Boards
A30 Analog Source Board

5. Amplitude and Phase Match

This test determines if the HP 3563A's amplitude and phase match between Channel 1 and Channel 2 are within the specified limits.

Specification

BNC shell of both channels grounded:

The amplitude deviation between channels will be no more than 0.1 dB, and the phase deviation no more than 0.5 degrees.

BNC center conductor of both channels grounded:

The amplitude deviation between channels will be no more than 0.8 dB, and the phase deviation no more than 8.5 degrees.

Required Test Equipment

- BNC TEE (m)(f)(f)
- BNC/Dual Banana Cable
- BNC Male/Dual Banana Female
- Female to Female Barrel
- BNC Cable (2) ≤ 30 cm

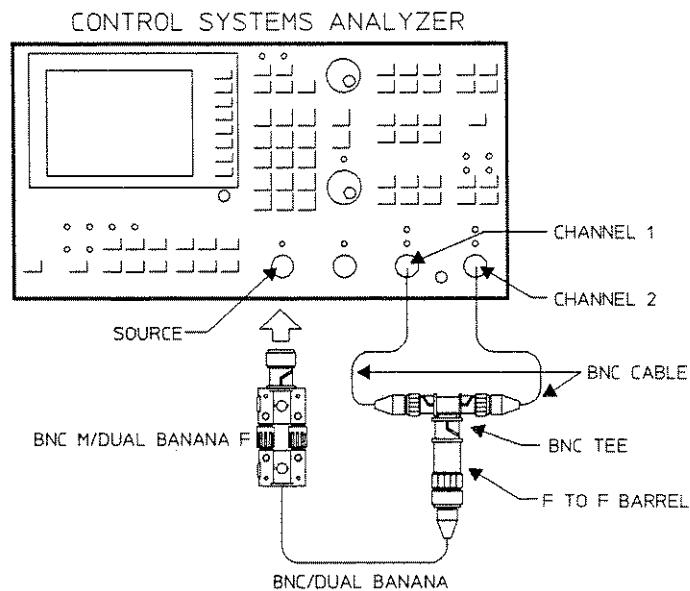

Figure 4-7. Amplitude and Phase Match Test Setup

Procedure

1. Connect the HP 3563A as shown in Figure 4-7. The cables to Channel 1 and Channel 2 must be the same length.
2. Press the HP 3563A keys as follows:

[Control]			
PRESET	RESET	
[Input Setup]			
CAL	SINGLE CAL	
[Input Setup]			
INPUT CONFIG	CHAN 1 AC	
	CHAN 2 AC	
	GROUND CHAN 1	
	GROUND CHAN 2	
[Input Setup]		[Entry]	
SELECT TRIG	0 V
	SOURCE TRIG	
[Measurement]			
WINDOW	UNIFRM (NONE)	
[Measurement]		[Entry]	
AVG	16 ENTER
	STABLE	
[Measurement]			
SOURCE	SOURCE TYPE PRIODC CHIRP

Performance Tests

5. Amplitude and Phase Match

[Display]
MEAS
DISP FREQ
RESP

[Display] [Entry]
SCALE X FIXD .375, 100 kHz
SCALE

3. Press the HP 3563A keys as follows:

[Input Setup] [Entry]
RANGE -47 dBVrms

[Measurement] [Entry]
SOURCE SOURCE -49 dBVrms
LEVEL

[Display] [Entry]
SCALE Y FIXD
SCALE -.2, .2 dB

[Control]
START

[Markers] [Entry]
Y1, .1dB

4. If the measurement is within the marker band, check PASS on the Performance Test Record for Part 1.

5. Press the HP 3563A keys as follows:

[Input Setup] [Entry]
RANGE 0 dBVrms

[Measurement] [Entry]
SOURCE SOURCE 0 dBVrms
LEVEL

[Control]
START

[Markers] [Entry]
Y -.1, .1dB

6. If the measurement is within the marker band, check PASS on the Performance Test Record for Part 2.

7. Press the HP 3563A keys as follows:

[Input Setup] [Entry]
 RANGE **10 dBVrms**

[Input Setup] [Entry]
 SOURCE **SOURCE** **10 dBVrms**
 LEVEL

[Control]
 START

[Markers] [Entry]
 Y **-.1, .1dB**

8. If the measurement is within the marker band, check PASS on the Performance Test Record for Part 3.

9. Press the HP 3563A keys as follows:

[Input Setup] [Entry]
 RANGE **-47 dBVrms**

[Measurement] [Entry]
 SOURCE **SOURCE** **-49 dBVrms**
 LEVEL

[Display]
 COORD **PHASE**

[Control]
 START

[Display] [Entry]
 SCALE **Y FIXD** **-1, 1 Degree**
 SCALE

[Markers] [Entry]
 Y **Y** **-.5, .5 Degree**
 VALUE

10. If the measurement is within the marker band, check PASS on the Performance Test Record for Part 4.

Performance Tests

5. Amplitude and Phase Match

11. Press the HP 3563A keys as follows:

[Input Setup] [Entry]
RANGE 0 dBVrms

[Measurement] [Entry]
SOURCE 0 dBVrms
 SOURCE
 LEVEL

[Control]
START

[Markers] [Entry]
Y Y -.5, .5 Degree
 VALUE

12. If the measurement is within the marker band, check PASS on the Performance Test Record for Part 5.

13. Press the HP 3563A keys as follows:

[Input Setup] [Entry]
RANGE 10 dBVrms

[Measurement] [Entry]
SOURCE 10 dBVrms
 SOURCE
 LEVEL

[Control]
START

[Markers] [Entry]
Y Y -.5, .5 Degree
 VALUE

14. If the measurement is within the marker band, check PASS on the Performance Test Record for Part 6.

15. Reverse one of the banana plug connectors so the center conductor of each channel's BNC is grounded.

16. Press the HP 3563A keys as follows:

```
[ Input Setup ]
  INPUT
  CONFIG ..... FLOAT
                CHAN 1
                .....
                FLOAT
                CHAN 2

[ Display ]
  COORD ..... MAG(dB)

[ Display ]
  SCALE ..... Y FIXD
                SCALE          [ Entry ]
                                -1,1 dB

[ Measurement ]
  SOURCE ..... SOURCE
                LEVEL          [ Entry ]
                                -13 dBVrms

[ Input Setup ]
  RANGE ..... [ Entry ]
                -13 dBVrms

[ Control ]
  START

[ Markers ]
  Y ..... Y
                VALUE          [ Entry ]
                                -.8, .8 dB
```

17. If the measurement is within the marker band, check PASS on the Performance Test Record for Part 7.

Performance Tests

5. Amplitude and Phase Match

18. Press the HP 3563A keys as follows:

[Input Setup]		[Entry]	
RANGE	8 dBVrms	
[Measurement]		[Entry]	
SOURCE	SOURCE 8 dBVrms
		LEVEL	
[Control]			
START			
[Markers]		[Entry]	
Y	Y -8, .8 dB
		VALUE	

19. If the measurement is within the marker band, check PASS on the Performance Test Record for Part 8.

20. Press the HP 3563A keys as follows:

[Input Setup]		[Entry]	
RANGE	-13 dBVrms	
[Measurement]		[Entry]	
SOURCE	SOURCE -13 dBVrms
		LEVEL	
[Display]			
COORD	PHASE	
[Control]			
START			
[Display]		[Entry]	
SCALE	Y FIXD -10, 10 Degree
		SCALE	
[Markers]		[Entry]	
Y	Y -8.5, 8.5 Degree
		VALUE	

21. If the measurement is within the marker band, check PASS on the Performance Test Record for Part 9.
22. Press the HP 3563A keys as follows:

```
[ Input Setup ]      [ Entry ]  
  RANGE          .....  8 dBVrms  
  
[ Measurement ]      [ Entry ]  
  SOURCE          .....  SOURCE  
                  SOURCE   LEVEL  
                  .....  8 dBVrms  
  
[ Control ]  
  START  
  
[ Markers ]          [ Entry ]  
  Y                  .....  -8.5, 8.5 Degree  
                  Y  
                  VALUE
```

23. If the measurement is within the marker band, check PASS on the Performance Test Record for Part 10.

If Test Fails

If this test fails, contact your local Hewlett-Packard sales and service office or have a qualified service technician see the following sections in the *HP 3563A Service Manual*:

Adjustments
Section III

2nd Pass Gain Adjustment
ADC Offset and Reference Adjustment
Input Flatness Adjustment
Input Attenuator Adjustments
Calibrator Adjustment

Troubleshooting
Section VII

A33, A35 Input Boards
A32, A34 Analog Digital Converter Boards
A30 Analog Source Board

6. Anti-Alias Filter Response

Signals with frequencies greater than 156 kHz may be shifted down into the 100 kHz frequency range as a result of the HP 3563A's 256 kHz sample rate. This test measures the ability of the 100 kHz low pass anti-alias filter to reject frequencies 156 kHz and greater.

Note



The frequency synthesizer may produce some spurious signals in the 0 to 100 kHz span. Ignore signals at frequencies other than those listed in the table when performing this test.

Specification

All signals aliasing into the 0 to 100 kHz frequency span will be attenuated at least 80 dB below the range setting.

Required Test Equipment

- Frequency Synthesizer
- Female to Female Barrel
- 50Ω feedthrough termination
- BNC Cable (3)
- BNC Tee (m)(f)(f)

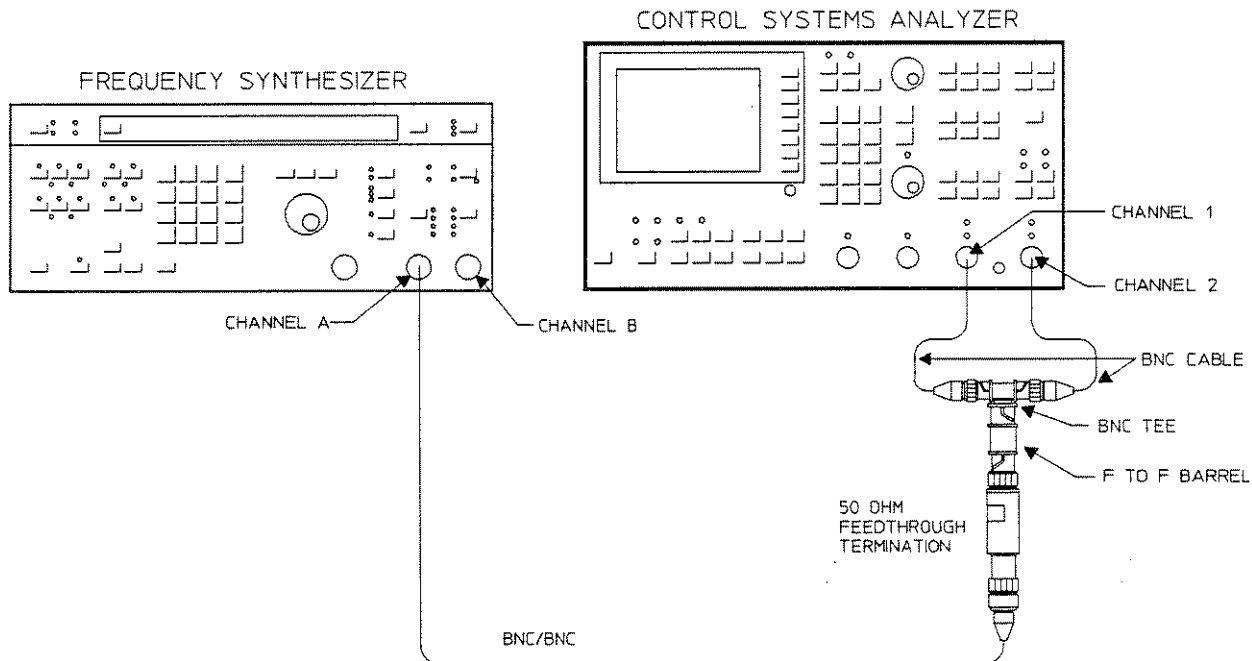

Figure 4-8. Anti-Alias Filter Response Test

Procedure

1. Connect the test instruments as shown in Figure 4-8.
2. Set the test instruments initially as follows:

Frequency Synthesizer

Function	SINE WAVE (~)
Frequency	156 kHz
Amplitude	1 Vrms
Phase	0 Degrees
dc Offset	0V
Modulation	OFF
Sweep	OFF

3. Press the HP 3563A keys as follows:

[Control]			
PRESET	RESET	
[Input Setup]			
CAL	SINGLE CAL	
[Input Setup]		[Entry]	
RANGE	1 Vrms	
[Measurement]		[Entry]	
AVG	16 ENTER
	STABLE	
[Measurement]			
WINDOW	FLAT TOP	
[Input Setup]			
INPUT CONFIG	GROUND CHAN 1	
	GROUND CHAN 2	

Performance Tests
 6. Anti-Alias Filter Response

[Display]
 A&B

[Display]
 UNITS P SPEC VOLTS
 UNITS RMS
 VOLTS

Table 4-8. Anti-Alias Filter

Signal Frequency	Alias Frequency
156 kHz	100 kHz
184 kHz	72 kHz
206 kHz	50 kHz
267 kHz	11 kHz

4. For each of the signal frequencies listed in Table 4-8 perform steps a through d:
 - a. Set the frequency synthesizer to the signal frequency in Table 4-8.
 - b. Press the HP 3563A keys as follows:

[Control]
 START

[Markers]
 X To alias frequency in Table 4-8.

- c. If the Ya reading is less than or equal to -80 dBVrms check PASS on the Performance Test Record for Channel 1.
- d. If the Yb reading is less than or equal to -80 dBVrms check PASS on the Performance Test Record for Channel 2.

If Test Fails

If this test fails, contact your local Hewlett-Packard sales and service office or have a qualified service technician see the following sections in the *HP 3563A Service Manual*:

Adjustments None
 Section III

Troubleshooting A32, A34 Analog Digital Converter Boards
 Section VIII

7. Frequency Accuracy

This test measures the frequency accuracy of the HP 3563A using the Frequency Synthesizer as a reference.

Specification

The frequency reading will not deviate from the actual signal frequency by more than 0.004%.

Required Test Equipment

Frequency Synthesizer
50Ω feedthrough termination
BNC Cable

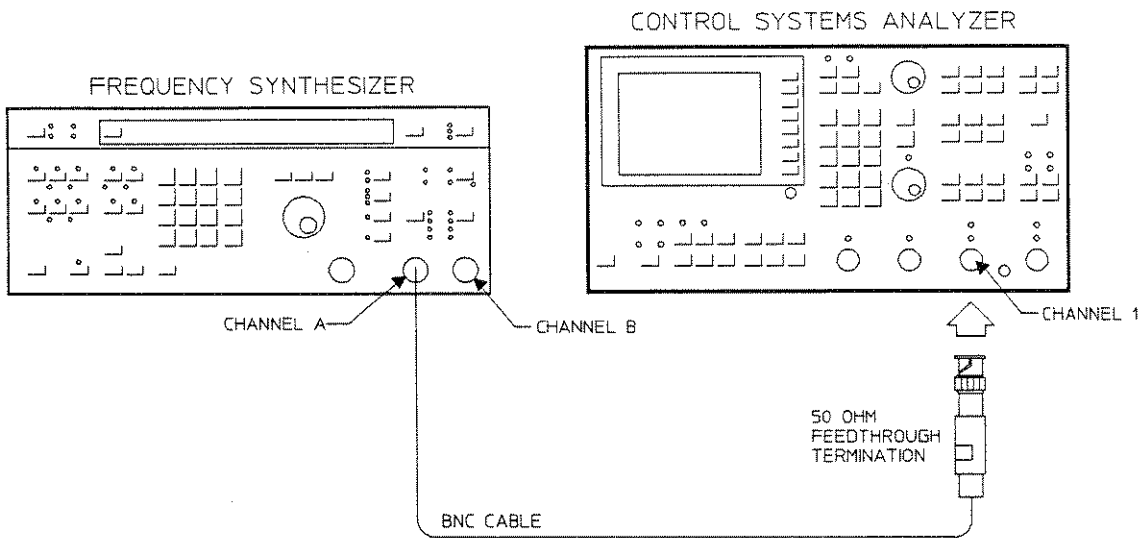

Figure 4-9. Frequency Accuracy Test Setup

Procedure

1. Connect the test equipment as shown in Figure 4-9.

2. Set the Frequency Synthesizer as follows:

Function	SINE WAVE (~)
Frequency	99 kHz
Amplitude	1 Vrms
Phase	0 Degrees
dc Offset	0V
Modulation	OFF
Sweep	OF

3. Press the HP 3563A keys as follows:

[Control]
PRESET RESET

[Input Setup]
CAL SINGLE
CAL

[Input Setup] [Entry]
RANGE 0 dBVrms

[Measurement] [Entry]
FREQ CENTER 99 kHz
FREQ
..... FREQ5 kHz
SPAN

[Measurement] [Entry]
AVG 2 ENTER
..... STABLE

[Control]
START

[Markers]
X

4. Record the X marker reading as the measured value on the Performance Test Record.

If Test Fails

If this test fails, contact your local Hewlett-Packard sales and service office or have a qualified service technician see the following sections in the *HP 3563A Service Manual*:

Adjustments
Section III

20.48 MHz Reference Adjustment

Troubleshooting
Section VIII

A31 Trigger Board

8. Input Coupling Insertion Loss

This test measures the insertion loss at 1 Hz due to the ac coupling capacitors. The amplitude of a 1 Hz signal is measured in both ac and dc coupled modes. The insertion loss is calculated as:

$$\frac{\text{dc Coupled Amplitude}}{\text{ac Coupled Amplitude}} = \text{Insertion Loss}$$

Specification

The insertion loss at 1 Hz due to the ac coupling capacitors will be less than 3 dB (41.3%).

Required Test Equipment

- Frequency Synthesizer
- 50Ω feedthrough termination
- BNC Tee (m)(f)(f)
- Female to Female Barrel
- BNC cable (3)

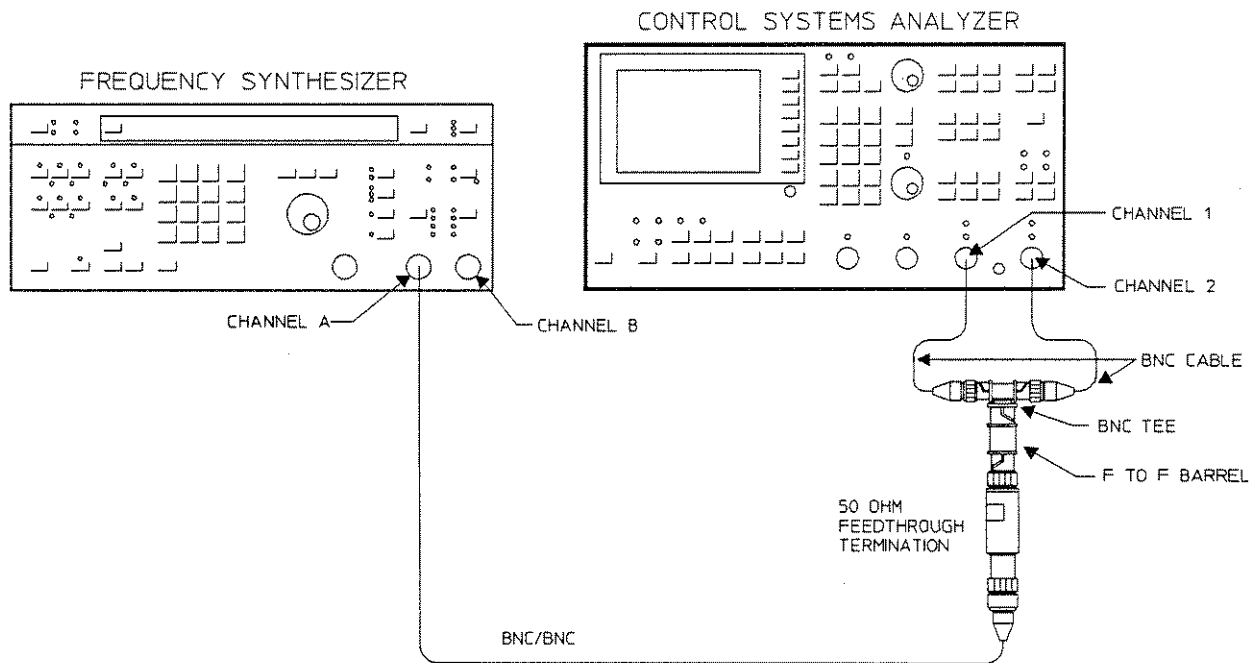

Figure 4-10. Input Coupling Insertion Loss Test Setup

Procedure

1. Connect the test equipment as shown in Figure 4-10.
2. Set the Frequency Synthesizer initially as follows:

Function	SINE WAVE (~)
Frequency	1 Hz
Amplitude	1 Vrms
Phase	0 Degrees
dc Offset	0V
Modulation	OFF
Sweep	OFF

3. Press the HP 3563A keys as follows:

[Control]			
PRESET	RESET	
[Input Setup]			
CAL	SINGLE CAL	
[Input Setup]		[Entry]	
RANGE	1 Vrms	
[Measurement]			[Entry]
FREQ	FREQ SPAN	100 Hz
[Measurement]			
WINDOW	UNIFORM (NONE)	
[Measurement]		[Entry]	
AVG	4	ENTER
	STABLE	
[Display]			
UNITS	P SPEC UNITS	VOLTS RMS
			VOLTS

Performance Tests

8. Input Coupling Insertion Loss

[Input Setup]
INPUT
CONFIG CHAN 1
AC

[Control]
START

Note



Wait for measurement to finish before proceeding. "Measurement Complete" will appear in the status line of the display.

[Markers] [Entry]
X 1 Hz XMRKR
SCALE

[Control] [Entry]
SAVE
RECALL SAVE
DATA # 1
ENTER
INPUT
CONFIG CHAN 1
DC

[Control]
START

[Operators]
MATH DIV SAVED
1

Note



Ignore math overflow message.

4. Record the Ya reading on the Performance Test Record for Channel 1.

5. Press the HP 3563A keys as follows:

```
[ Display ]
  B

[ Input Setup ]
  INPUT
  CONFIG .....  CHAN 2
                   AC

[ Control ]
  START

[ Markers ]
  X .....  X MRKR
            SCALE

[ Control ]                               [ Entry ]
  SAVE                                     SAVE .....  2
  RECALL .....  DATA #
            .....  ENTER

[ Input Setup ]
  INPUT
  CONFIG .....  CHAN 2
                   DC

[ Control ]
  START
```

Note



Wait for measurement to finish before proceeding. "Measurement Complete" will appear in the status line of the display.

```
[ Operators ]
  MATH .....  DIV .....  SAVED
                                     2
```

6. Record the Yb reading on the Performance Test Record for Channel 2.

Performance Tests
8. Input Coupling Insertion Loss

If Test Fails

If this test fails, contact your local Hewlett-Packard sales and service office or have a qualified service technician see the following sections in the *HP 3563A Service Manual*:

Adjustments

None

Troubleshooting
Section VIII

A33, A35 Input Boards

9. Single Channel Phase Accuracy

This test measures the phase accuracy of the HP 3563A relative to the phase of the trigger signal. The Frequency Synthesizer is used to input a square wave to one channel and the external trigger input.

Specification

When the BNC shell of a channel is grounded, the marker phase reading will not deviate from the actual phase of the signal relative to the trigger by more than:

Frequency Range	Phase Deviation
0 Hz to <10 kHz	± 2.5 degrees
10 kHz to 100 kHz	± 12.0 degrees

When the BNC center conductor of a channel is grounded, the marker phase reading will not deviate from the actual phase of the signal relative to the trigger by more than:

Frequency Range	Phase Deviation
0 to <10 kHz	± 6.5 degrees
10 kHz to 100 kHz	± 16.0 degrees

Required Test Equipment

Frequency Synthesizer
50Ω feedthrough termination
BNC Tees (2) (m)(f)(f)
Female to Female Barrel

BNC/Dual Banana
BNC (m)/Banana (f)
BNC Cable (2)
BNC Cable: length ≤ 30 cm (2)

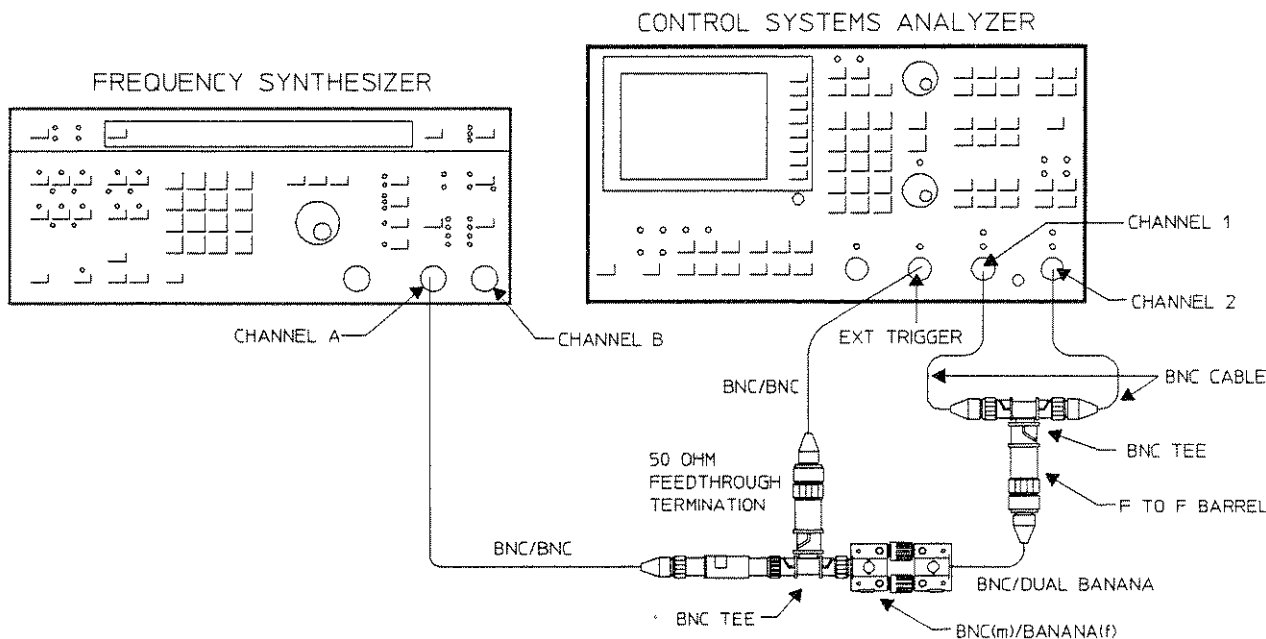



Figure 4-11. Single Channel Phase Accuracy Test Setup

9. Single Channel Phase Accuracy

Procedure

1. Connect the test instruments as shown in Figure 4-11.

2. Set the Frequency Synthesizer as follows:

Function	Square Wave ()
Frequency	9 kHz
Amplitude	1 Vrms
DC Offset	0 Vdc
Phase	0 Degrees
Modulation	OFF
Sweep	OFF

3. Press the HP 3563A keys as follows:

[Control]			
PRESET	RESET	
[Input Setup]			
CAL	SINGLE CAL	
[Measurement]			
SELECT MEAS	POWER SPEC	
[Input Setup]			
INPUT CONFIG	GROUND CHAN 1	
	GROUND CHAN 2	
[Measurement]		[Entry]	
AVG	5 ENTER
	STABLE	
	TIM AV ON	

```

[ Measurement ]
WINDOW ..... UNIFRM
                (NONE)

[ Input Setup ] [ Entry ]
SELECT
TRIG ..... 0 V

[ Display ]
MEAS
DISP ..... FILTRD ..... LINEAR
                INPUT ..... SPEC1

[ Display ]
B ..... LINEAR
                SPEC2

[ Display ]
A&B

[ Display ]
COORD ..... PHASE
    
```

Table 4-9. Single Channel Phase Accuracy

Signal Frequency	Trigger Slope	Trigger Type
9 kHz	POS	INPUT Channel 1
9 kHz	POS	INPUT Channel 2
9 kHz	POS	EXTERNAL
9 kHz	NEG	EXTERNAL
99 kHz	POS	INPUT Channel 1
99 kHz	POS	INPUT Channel 2
99 kHz	POS	EXTERNAL

4. For each of the frequencies listed in Table 4-9 perform steps a through d:

a. Set the Frequency Synthesizer as follows:

Frequency To signal frequency in Table 4-9.

b. Press the HP 3563A keys as follows:

```

[ Input Setup ]
SELECT
TRIG ..... To trigger slope in Table 4-9.
                ..... To trigger type in Table 4-9.
    
```

Performance Tests

9. Single Channel Phase Accuracy

To select an external trigger type, press:

..... MORE TYPES EXT TRIG

[Control]
START

[Markers]
X To signal frequency in Table 4-9.

c. Record the Ya marker reading on the Performance Test Record for CHANNEL 1 measured value, BNC shell grounded.

d. Record the Yb marker reading on the Performance Test Record for CHANNEL 2 measured value, BNC shell grounded.

5. Reverse one of the banana plug connectors so the center conductor of each channel's BNC is grounded.

6. Press the HP 3563A keys as follows:

[Input Setup]
INPUT CONFIG FLOAT CHAN 1
..... FLOAT CHAN 2

7. Repeat steps 4a through 4d for the BNC center conductors grounded.

If Test Fails

If this test fails, contact your local Hewlett-Packard sales and service office or have a qualified service technician see the following sections in the *HP 3563A Service Manual*:

Adjustments	None
Troubleshooting Section VII	A33, A35 Input Boards A32, A34 Analog Digital Converter Boards A31 Trigger Board A6 Digital Filter Controller A1 Digital Source

10. Digital Input/Output

This test verifies the instrument's ability to take a digital measurement. The digital source is used to verify the operation of Input Pod 1 and Input Pod 2, using both internal and external paths. The digital source is used to verify the Qualifier Pod, Pod Q, by using an external path.

Required Test Equipment

A40 Test Board
8-bit Probe Cables (3)
16-bit Probe Cables (3)
Pattern Generator Probe Lead Set

Note



If the A40 Test Board is not available, see the alternate setup following this procedure.

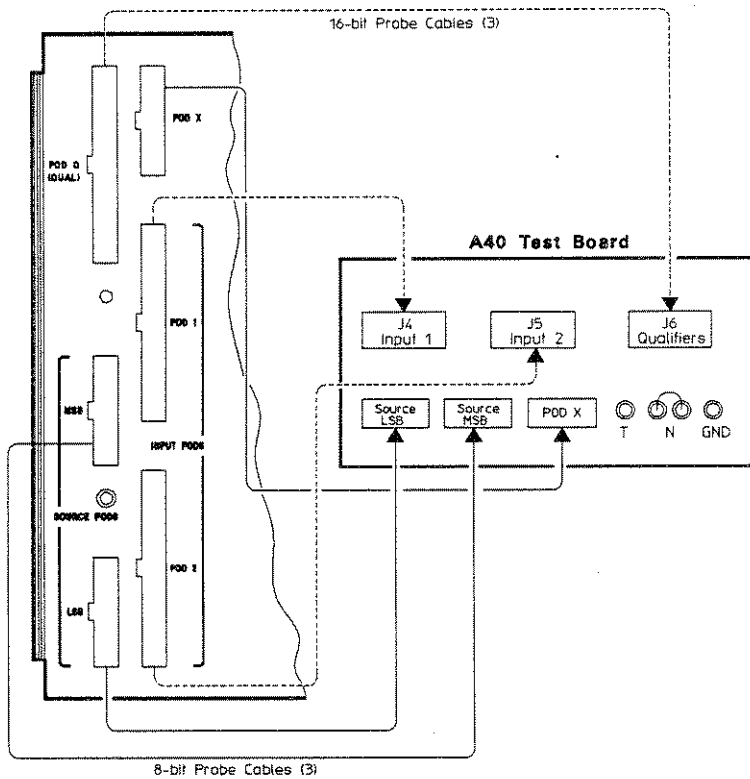

Figure 4-12. Digital Input/Output Test Setup

Procedure

1. Press the Line switch OFF.
2. Using the cables, connect the test board to the rear panel of the HP 3563A as shown in Figure 4-12. Verify the jumper is in the normal position (N).
3. Press the Line switch ON.
4. Press the HP 3563A keys as follows:

```
[ Control ]  
  PRESET  .....  RESET  
  
[ Control ]  
  SPCL    .....  SERVIC  .....  TEST  
  FCTN    .....  TEST    .....  INPUT  
                                     .....  INTERN  
                                     .....  PATH
```

5. If the test passes, check PASS on the Performance Test Record for Internal Path.
6. Press the HP 3563A keys as follows:

```
.....  INPUT  
                POD 1
```

Note



Wait for the test to finish before proceeding. This test takes approximately 1 minute to complete.

7. If the test passes, check PASS on the Performance Test Record for Input Pod 1.
8. Press the HP 3563A keys as follows:

```
.....  INPUT  
                POD 2
```

Note



Wait for the test to finish before proceeding. This test takes approximately 1 minute to complete.

9. If the test passes, check PASS on the Performance Test Record for Input Pod 2.

10. Press the HP 3563A keys as follows:

..... QUALFR
POD

Note



Wait for the test to finish before proceeding. This test takes approximately 1 minute to complete.

11. If the test passes, check PASS on the Performance Test Record for Qualifier Pod.

12. Press the HP 3563A keys as follows:

[Control]
SPCL
FCTN SERVIC TEST
 TEST SOURCE
 ARBITRARY

Note



This test takes approximately 1 minute to complete.

13. If the test passes, check PASS on the Performance Test Record for Arbitrary Source.

Alternate Setup for Digital Input/Output Test

Use this test method to verify the operation of the digital input/output if the A40 Test Board is not available.

Required Test Equipment

- 16-bit input probe cables (3)
- 16-bit input probe pods (3)
- 8-bit output probe cables (3)
- Pattern Generator Probe Lead Set (3)
- Grabbers (4 packages of 20 each)

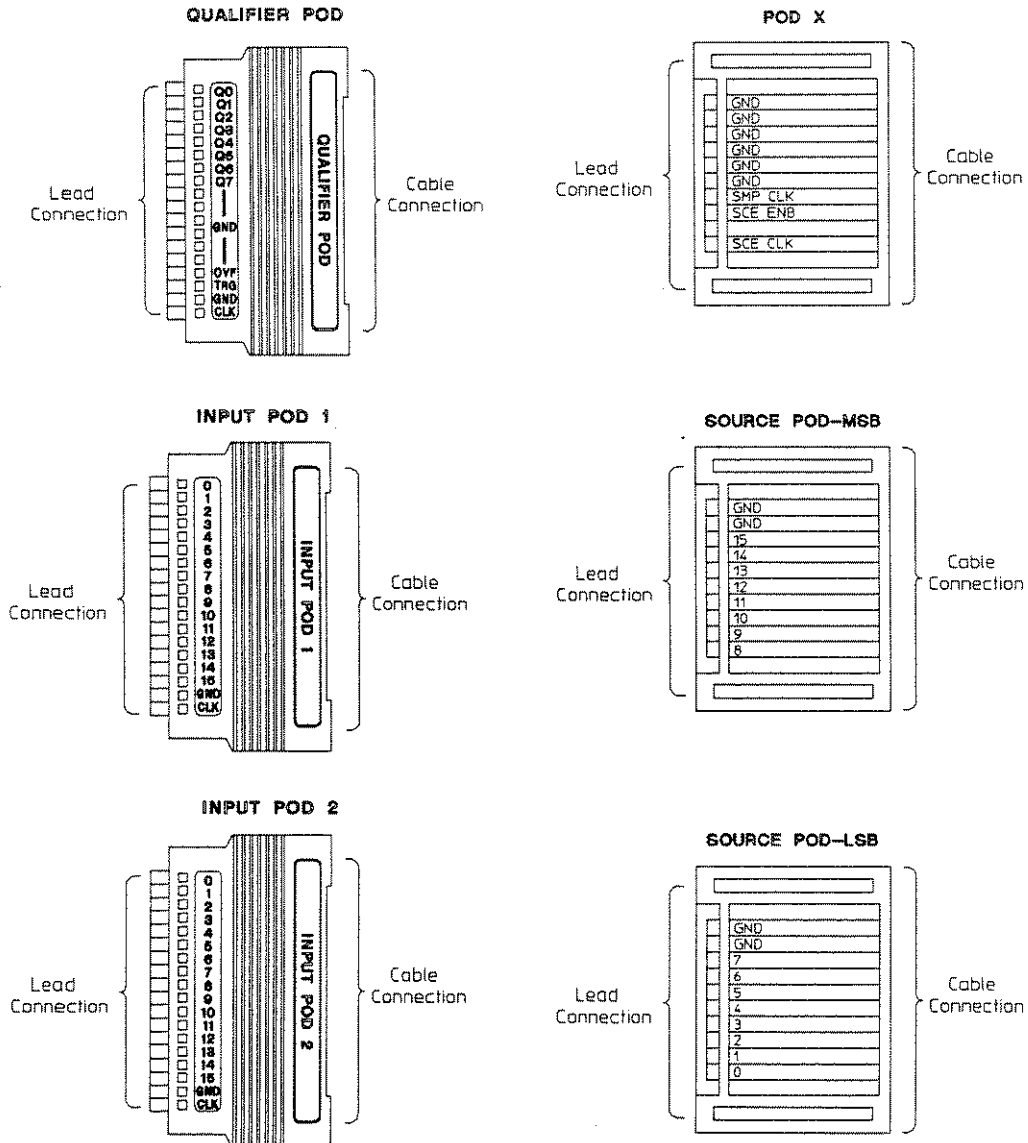

Figure 4-13. Pod Line Description

Table 4-10. Cable Connections

Source LSB Pod Line	Input Pod 1 Line	Input Pod 2 Line	Qualifier Pod Line
0	0	0	Q0 (0)
1	1	1	Q1 (1)
2	2	2	Q2 (2)
3	3	3	Q3 (3)
4	4	4	Q4 (4)
5	5	5	Q5 (5)
6	6	6	Q6 (6)
7	7	7	Q7 (7)
GND	GND	GND	nc ¹
Source MSB Pod Line	Input Pod 1 Line	Input Pod 2 Line	Qualifier Pod Line
8	8	8	TRG (15)
9	9	9	nc
10	10	10	nc
11	11	11	nc
12	12	12	nc
13	13	13	nc
14	14	14	nc
15	15	15	nc
GND	GND	GND	nc
Pod X Line	Input Pod 1 Line	Input Pod 2 Line	Qualifier Pod Line
SCE CLK	CLK	CLK	CLK
GND	GND	GND	GND

¹ No Connection

Procedure

1. Press the Line switch OFF.
2. Connect the six probe pods to the six probe cables.

Hint

The self-tests for Input Pod 1, Input Pod 2 and the Qualifier Pod, can be run independently. The test setup may be easier if you connect the Input Pods and the Qualifier Pod one at a time to the Source and Pod X lines.

Performance Tests

10. Digital Input/Output

3. Connect the grabbers to the ends of the probe pods.
4. Install the three 16-bit input probe cables into the analyzer's Pod Q, Input Pod 1, and Input Pod 2 rear-panel connectors.
5. Install the three 8-bit output probe cables into the Source's LSB Pod, the Source's MSB Pod, and Pod X rear-panel connectors.
6. Refer to Figure 4-13 for the description of each pod line. Connect the cables using the grabbers as indicated in Table 4-10. Connect the lines in each row together.
7. Press the Line switch ON.
8. Press the HP 3563A keys as follows:

```
[ Control ]
  PRESET    .....    RESET
```

```
[ Control ]
  SPCL
  FCTN      .....    SERVIC    .....    TEST
                                     TEST    INPUT
                                     .....
                                     DIGITAL .....    INTERN
                                                    PATH
```

9. If the test passes, check PASS on the Performance Test Record for Internal Path.

10. Press the HP 3563A keys as follows:

```
.....    INPUT
          POD 1
```

Note



Wait for the test to finish before proceeding. This test takes approximately 1 minute to complete.

11. If the test passes, check PASS on the Performance Test Record for Input Pod 1.

12. Press the HP 3563A keys as follows:

```
.....    INPUT
          POD 2
```

Note



Wait for the test to finish before proceeding. This test takes approximately 1 minute to complete.

13. If the test passes, check PASS on the Performance Test Record for Input Pod 2.
14. Press the HP 3563A keys as follows:

..... QUALFR
 POD

Note



Wait for the test to finish before proceeding. This test takes approximately 1 minute to complete.

15. If the test passes, check PASS on the Performance Test Record for Qualifier Pod.
16. Press the HP 3563A keys as follows:

[Control]
 SPCL
 FCTN SERVIC TEST
 TEST SOURCE
 ARBITRARY

Note



This test takes approximately 1 minute to complete.

17. If the measurements pass, check PASS on the Performance Test Record for Arbitrary Source.

If Test Fails

If any of the tests fails, start by checking the connections. If the connections are correct, contact your local Hewlett-Packard sales and service office or have a qualified service technician see the following sections in the *HP 3563A Service Manual*:

Adjustments
Section III

None

Troubleshooting
Section VII

A10 Digital I/O
A20 Digital Interface
A21 Digital Interface

11. Input Impedance

This test measures the input impedance of the HP 3563A as a series resistance and capacitance. The digital multimeter is used to measure the input resistance directly. The input capacitance is then measured by inputting a 100 kHz signal from the synthesizer. This equation is used to calculate the capacitance:

$$C = 15.92 \times 10^{-12} \sqrt{\frac{V_{in}^2}{V_c^2} - 1.210}$$

Note An LCR meter can be used to measure the input capacitance directly.



Specification

Input Resistance (R) = 1 M Ω \pm 50 k Ω (5%)

Input Capacitance (C) \leq 100 pF

Required Test Equipment

Frequency Synthesizer

50 Ω feedthrough termination

Digital Voltmeter

BNC/Dual Banana Cable

100 k Ω Resistor (See Figure 4-14)

BNC/BNC Cable

Resistance	Tolerance	Power	HP Part Number
100 k Ω	1%	0.25 W	0757-0465

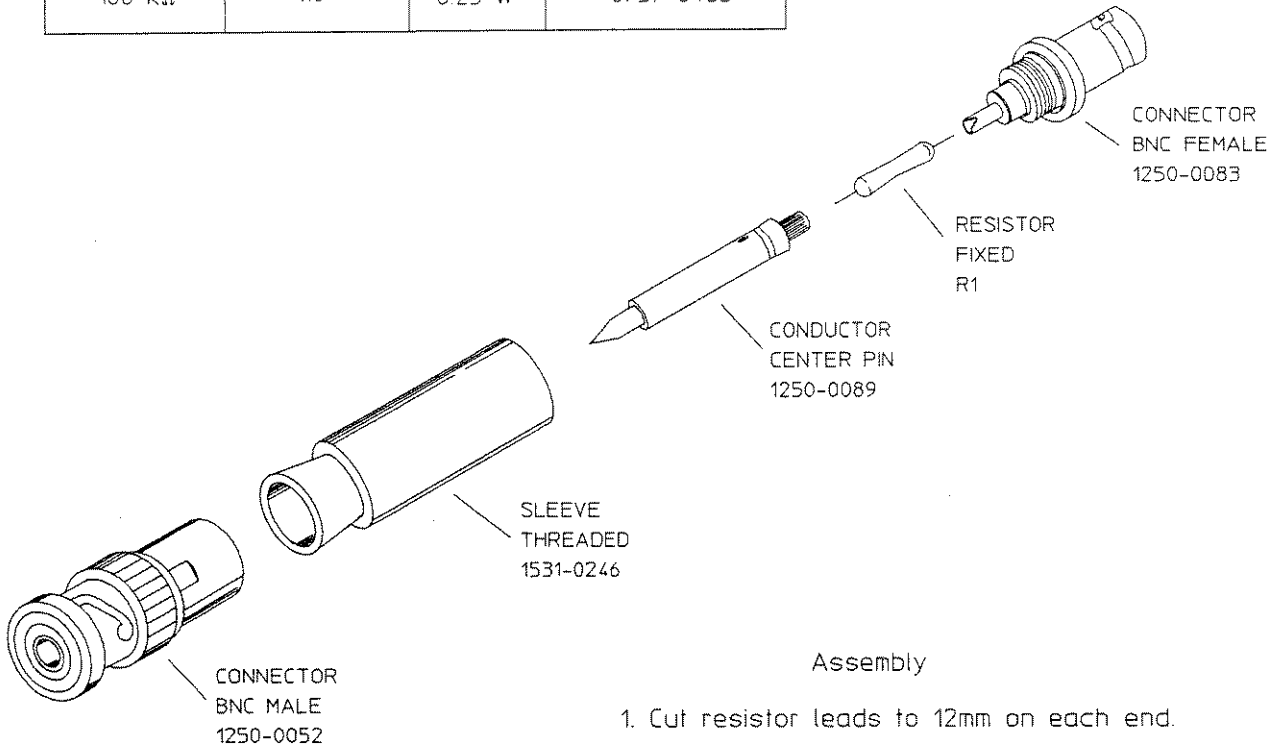

Assembly

1. Cut resistor leads to 12mm on each end.
2. Solder one resistor lead to the center conductor of the BNC FEMALE connector.
3. Solder the CONDUCTOR CENTER PIN to the other lead of the resistor.
4. Screw the SLEEVE and the BNC MALE connector into place. Tighten securely.

Figure 4-14. Constructing Feedthrough

Input Resistance Test

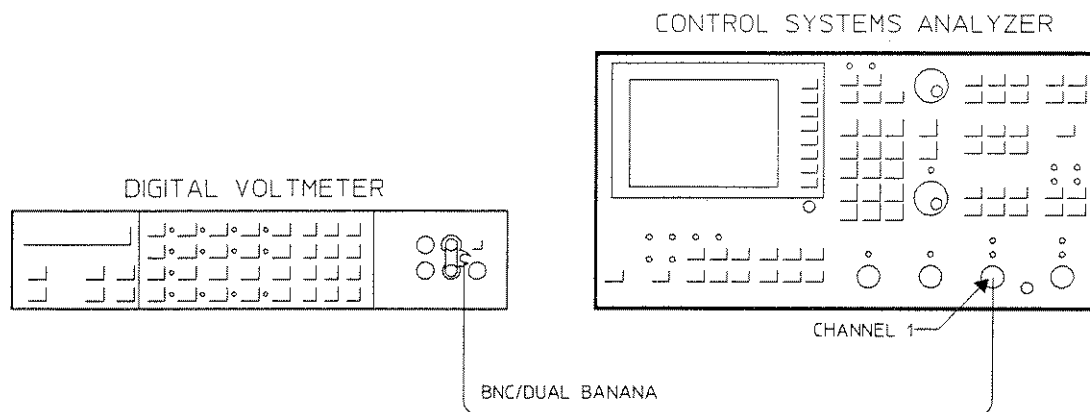

Figure 4-15. Input Resistance Test Setup

Procedure

1. Connect the test instruments as shown in Figure 4-15.

2. Set the digital voltmeter initially as follows:

Function	2 WIRE OHM
Range	AUTO
Trigger	INTERNAL
Sample Rate	Maximum
High Resolution	ON
Auto Cal	ON

3. Press the HP 3563A keys as follows:

[Control]		
PRESET	RESET
[Input Setup]		
CAL	SINGLE CAL

```
[ Input Setup ]
  INPUT
  CONFIG ..... GROUND
                CHAN 1
                .....
                GROUND
                CHAN 2
```

```
[ Input Setup ] [ Entry ]
  RANGE ..... 20 dBVrms
```

Table 4-11. Resistance Measurement

Range Setting	Specification	
	Lower Limit	Upper Limit
20 dBVrms	950k	1050k
0 dBVrms	950k	1050k
-13 dBVrms	950k	1050k

4. For each of the range settings listed in Table 4-11 perform steps a and b:

a. Press the HP 3563A keys as follows;

```
[ Input Setup ]
  RANGE ..... To the range setting in Table 4-11.
```

b. Record the digital voltmeter reading on the Performance Test Record.

5. Change the BNC input connector to Channel 2 and repeat steps 4a and 4b.

Input Capacitance Test

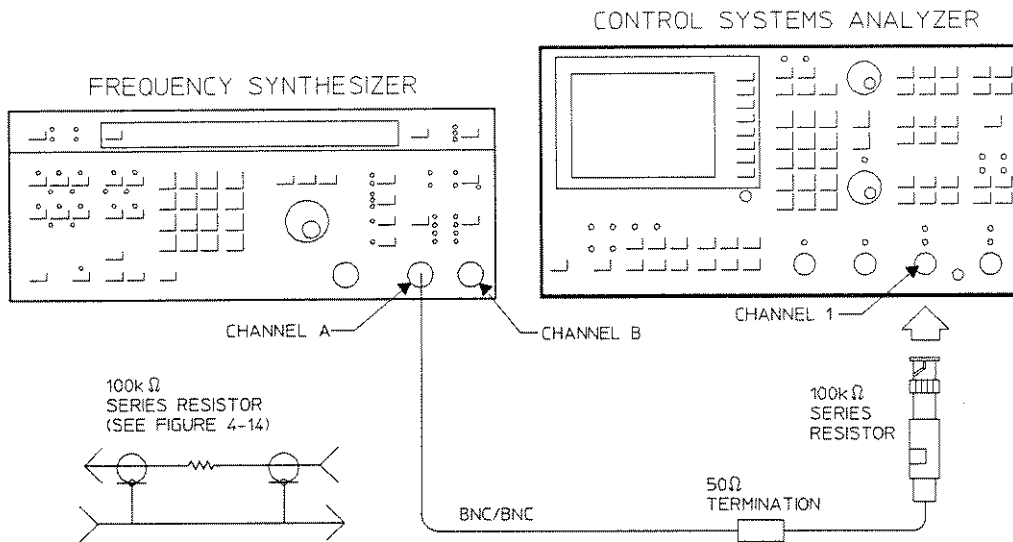

Figure 4-16. Input Capacitance Test Setup

Procedure

1. Connect the test instruments as shown in Figure 4-16.
2. Set the Frequency Synthesizer as follows:

Function	Sine Wave (\sim)
Frequency	100 kHz
Amplitude	1 Vrms
Phase	0 Degrees
dc Offset	0 V
Modulation	OFF
Sweep	OFF
High Voltage	ON

3. Press the HP 3563A keys as follows:

[Control]			
PRESET	RESET	
[Input Setup]			
CAL	AUTO	
		OFF	
[Measurement]		[Entry]	
AVG	16 ENTER
	STABLE	
[Input Setup]			
INPUT			
CONFIG	CHAN 1	
		AC	
	CHAN 2	
		AC	
	GROUND	
		CHAN 1	
	GROUND	
		CHAN 2	
[Input Setup]		[Entry]	
RANGE	0 dBVrms	
[Control]			
START			
[Display]			
UNITS	P SPEC VOLTS
		UNITS	RMS
		 VOLTS
[Display]			
COORD	MAG	
		(LIN)	
[Markers]		[Entry]	
X	100 kHz	

4. Record the V_a amplitude reading in the V_c position of the Performance Test Record for Channel 1.

Performance Tests

5. Move the setup to Channel 2.
6. Press the HP 3563A keys as follows:

[Display]
 B

[Control]
 START

[Display]
 COORD **MAG**
 (LIN)

7. Record the Yb amplitude reading in the Vc position of the Performance Test Record for Channel 2.
8. Remove the 100 k Ω resistor from the signal path and connect the BNC cable with the 50 Ω termination directly to the HP 3563A's Channel 1 input connector.
9. Press the HP 3563A keys as follows:

[Display]
 A

[Control]
 START

10. Record the Ya amplitude reading in the Vin position of the Performance Test Record for Channel 1.
11. Connect the 50 Ω termination to Channel 2.
12. Press the HP 3563A keys as follows:

[Display]
 B

[Control]
 START

13. Record the Yb amplitude reading in the Vin position of the Performance Test Record for Channel 2.
14. Use the equation given on the Performance Test Record to calculate the input capacitance.

If Test Fails

If this test fails, contact your local Hewlett-Packard sales and service office or have a qualified service technician see the following sections in the *HP 3563A Service Manual*:

Adjustments
Section III

None

Troubleshooting
Section VIII

A33, A35 Input Boards

12. Harmonic Distortion

This test measures the harmonic distortion generated in the HP 3563A when a full scale input is present.

Specification

The relative amplitude of all harmonics will be at least 80 dB below the fundamental amplitude.

Required Test Equipment

Low Distortion Oscillator
600 Ω feedthrough termination
BNC Tee (m)(f)(f)
Female to Female Barrel
Single Banana/Single Banana Cable
BNC/Dual Banana Cable
BNC Cable (2) \leq 30 cm

Harmonic Distortion Test One

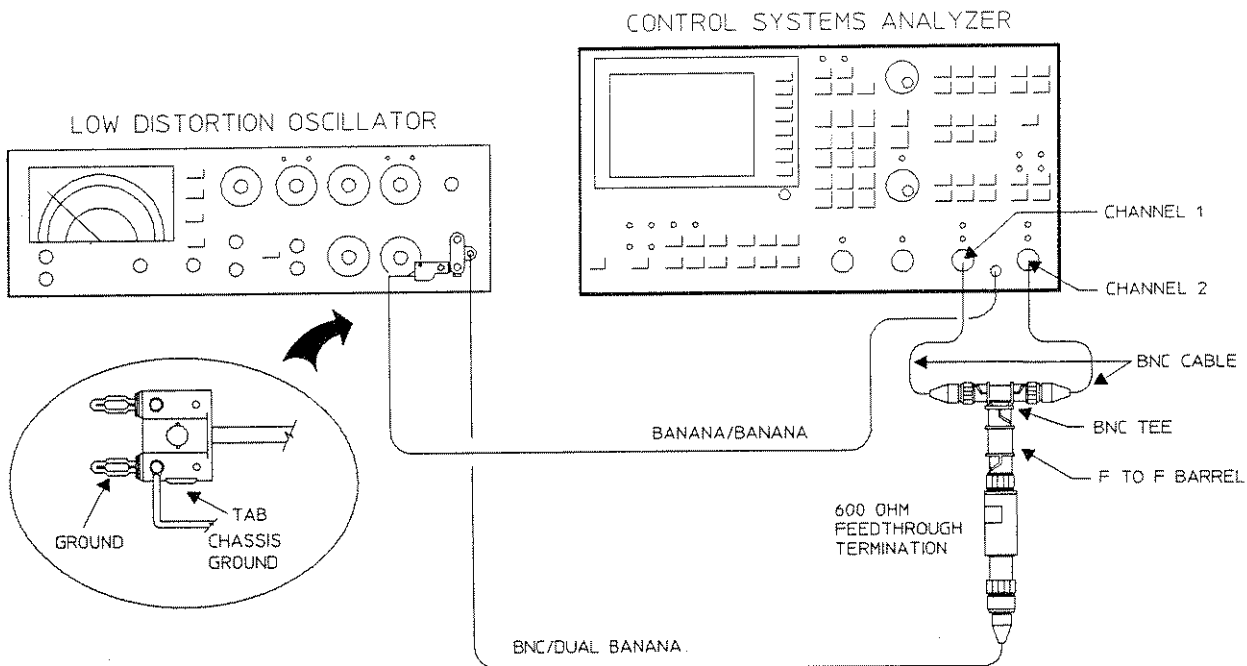

Figure 4-17. Harmonic Distortion Test One Setup

Procedure

1. Connect the test instruments as shown in Figure 4-17.
2. Set the Low Distortion Oscillator initially as follows:

Frequency	49 kHz
Amplitude	1 Vrms

Performance Tests
 12. Harmonic Distortion

3. Press the HP 3563A keys as follows:

[Control]				
PRESET	RESET		
[Input Setup]				
CAL	SINGLE		
		CAL		
[Input Setup]		[Entry]		
RANGE	0 dBVrms		
[Input Setup]				
INPUT		CHAN 1		
CONFIG	AC		
	CHAN 2		
		AC		
	GROUND		
		CHAN 1		
	GROUND		
		CHAN 2		
[Measurement]				
WINDOW	FLAT TOP		
[Display]				
UNITS	P SPEC	VOLTS
		UNITS		RMS
			VOLTS

Table 4-12. Harmonic Frequencies

Oscillator Coarse Frequency	Signal Frequency	Harmonic Number	Harmonic Frequency
49 kHz	49500 Hz	2nd	99 kHz
32 kHz	33000 Hz	3rd	99 kHz
24 kHz	24750 Hz	4th	99 kHz
19 kHz	19800 Hz	5th	99 kHz

4. For each of the signal frequencies listed in Table 4-12 perform steps a through g:

a. Set the Low Distortion Oscillator as follows:

Frequency To coarse frequency in Table 4-12.

b. Press the HP 3563A keys as follows:

[Measurement]
FREQ CENTER To signal frequency in Table 4-12.
FREQ

[Measurement]
AVG AVG
OFF

[Control]
START

[Display]
SINGLE

[Markers]
X To signal frequency in Table 4-12.

c. Adjust the Low Distortion Oscillator's frequency vernier until it equals the signal frequency.

d. Adjust the Low Distortion Oscillator's amplitude vernier until $Y_a = 0 \text{ dBV}_{\text{rms}}$
 $\pm 01 \text{ dBV}_{\text{rms}}$.

Performance Tests
12. Harmonic Distortion

e. Press the HP 3563A keys as follows:

[Display]
A&B

[Measurement] [Entry]
AVG **4** ENTER

 **STABLE**

[Measurement]
FREQ **MAX**
 SPAN

[Control]
START

[Markers] [Entry]
X **99 kHz**

f. Record the Ya marker amplitude reading on the Performance Test Record as the harmonic frequency amplitude for Channel 1.

g. Record the Yb marker amplitude reading on the Performance Test Record as the harmonic frequency amplitude for Channel 2.

Note



The HP 3563A is a mathematical instrument and can not read an amplitude of 0. As a result the HP 3563A may read amplitudes at or near 0 as very low values (such as -780 dB.)

Harmonic Distortion Test Two

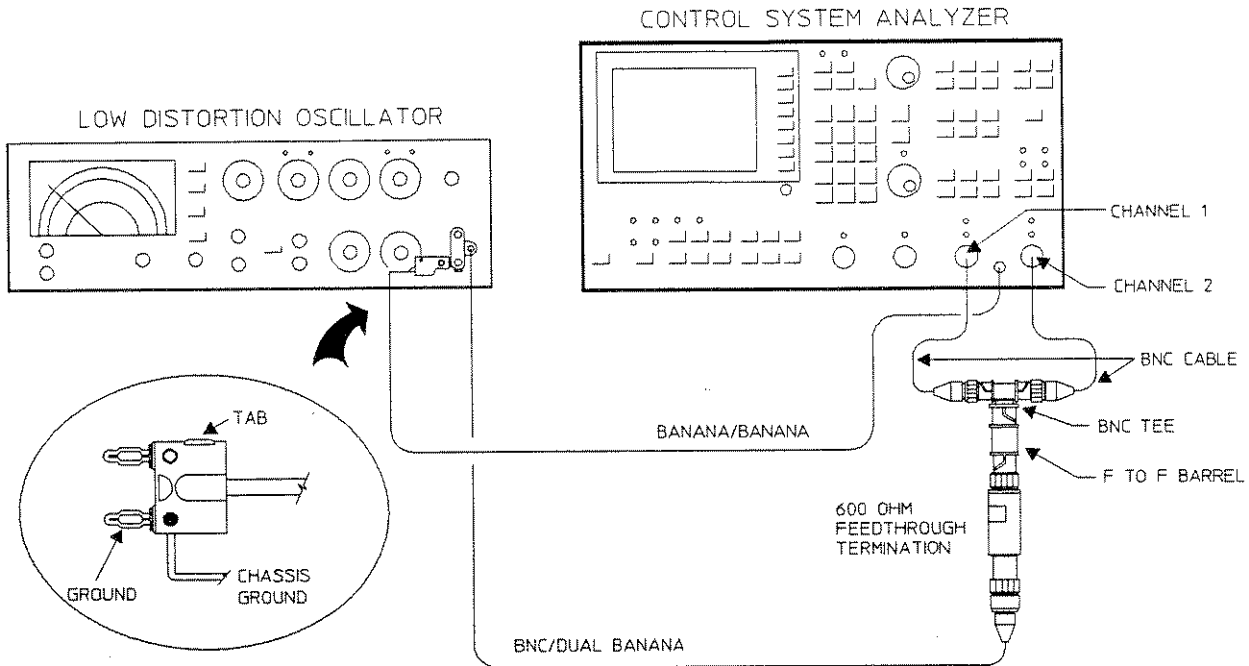

Figure 4-18. Harmonic Distortion Test Two Setup

Procedure

1. Connect the test instruments as shown in Figure 4-18. The chassis ground cable must go to the ground terminal of the Low Distortion Oscillator.
2. Press the HP 3563A keys as follows:

```
[ Input Setup ]
  INPUT
  CONFIG ..... FLOAT
                                     CHAN 1
                                     .....
                                     FLOAT
                                     CHAN 2
```

Table 4-13. Harmonic Frequencies

Oscillator Coarse Frequency	Signal Frequency	Harmonic Number	Harmonic Frequency
49 kHz	49500 Hz	2nd	99 kHz
32 kHz	33000 Hz	3rd	99 kHz
24 kHz	24750 Hz	4th	99 kHz
19 kHz	19800 Hz	5th	99 kHz

3. For each of the signal frequencies listed in Table 4-13 perform steps a through g:

a. Set the Low Distortion Oscillator as follows:

Frequency To coarse frequency in Table 4-13.

b. Press the HP 3563A keys as follows:

[Measurement]
FREQ CENTER To signal frequency in Table 4-13.
 FREQ

[Measurement]
AVG AVG
 OFF

[Control]
START

[Display]
SINGLE

[Markers]
X To signal frequency in Table 4-13.

c. Adjust the Low Distortion Oscillator's frequency vernier until it equals the signal frequency.

d. Adjust the Low Distortion Oscillator's amplitude vernier until $Y_a = 0 \text{ dBV}_{\text{rms}} + 01 \text{ dBV}_{\text{rms}}$.

e. Press the HP 3563A keys as follows:

[Display]
A&B

[Measurement] [Entry]
AVG **4** ENTER
 STABLE

[Measurement]
FREQ MAX
SPAN

[Control]
START

[Markers] [Entry]
X 99 kHz

- a. Record the Ya marker amplitude reading on the Performance Test Record as the harmonic frequency amplitude for Channel 1.
- b. Record the Yb marker amplitude reading on the Performance Test Record as the harmonic frequency amplitude for Channel 2.

If Test Fails

If this test fails, contact your local Hewlett-Packard sales and service office or have a qualified service technician see the following sections in the *HP 3563A Service Manual*:

Adjustments
Section III

2nd Pass Gain Adjustment
ADC Offset and Reference Adjustment

Troubleshooting
Section VII

A33, A35 Input Boards
A32, A34 Analog Digital Converter Boards

13. Intermodulation Distortion

This test measures the level of the intermodulation distortion products generated within the HP 3563A to the 4th order.

The Frequency Synthesizer may produce some spurious signals in the 0 to 100 kHz span. Ignore signals at frequencies other than those listed in the tables when performing this test.

Specification

The amplitude of all intermodulation products will be at least 80 dB below the fundamental amplitude.

Required Test Equipment

Frequency Synthesizer
1 k Ω resistors (2) (See Figure 4-20)
BNC Tee (2) (m)(f)(f)
BNC (m)/Dual Banana
BNC to Banana Cable
(2) Female to Female Barrel
BNC/BNC Cable (2)
Single Banana to Single Banana
BNC/BNC \leq 30 cm (2)

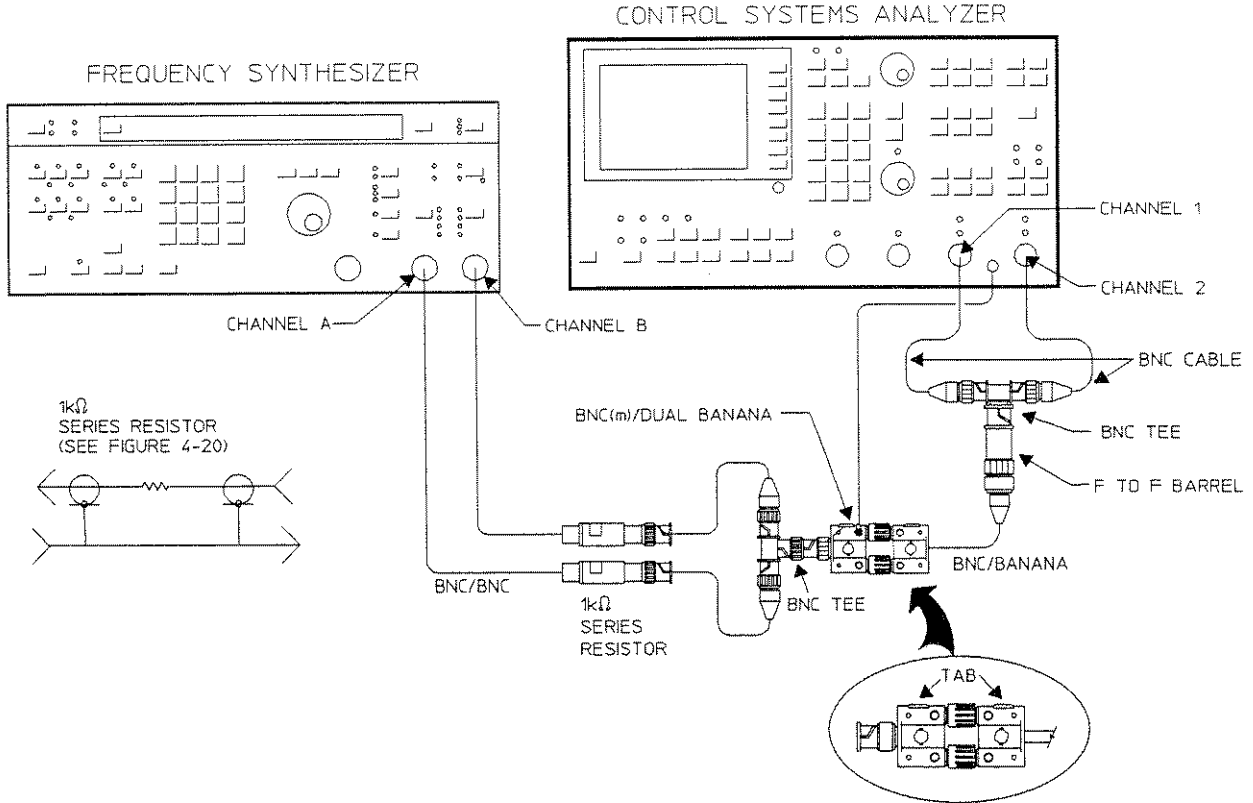

Figure 4-19. Intermodulation Distortion Test One Setup

Note

If the "COMBINED" mode is used on the Frequency Synthesizer, output from Channel A with one 50Ω termination instead of the 1 kΩ series resistors.

Intermodulation Distortion Test Measurement One

Resistance	Tolerance	Power	HP Part Number
1 k Ω	1%	0.25 W	0757-0465

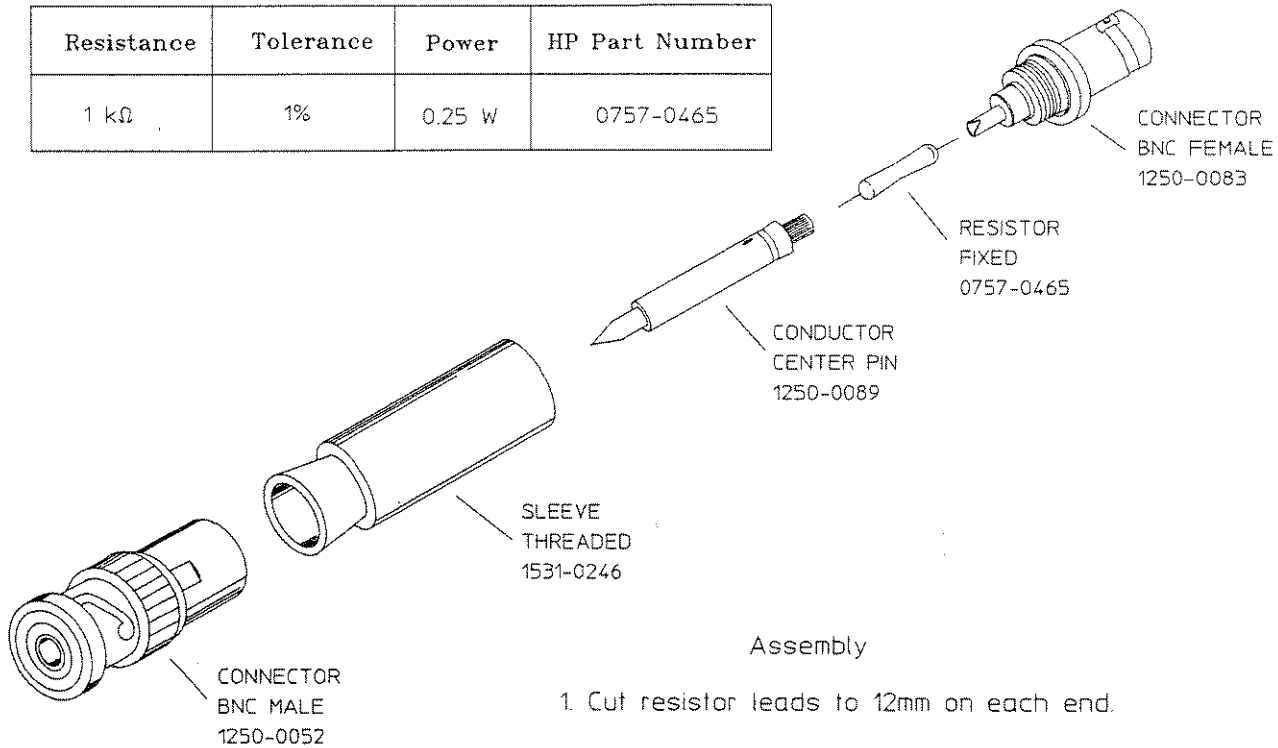

Assembly

1. Cut resistor leads to 12mm on each end.
2. Solder one resistor lead to the center conductor of the BNC FEMALE connector.
3. Solder the CONDUCTOR CENTER PIN to the other lead of the resistor.
4. Screw the SLEEVE and the BNC MALE connector into place. Tighten securely.

Figure 4-20. Constructing a Feedthrough

Procedure

1. Connect the test instruments as shown in Figure 4-19. Keep the connecting cables as short as possible.
2. Set the test instruments initially as follows:

Frequency Synthesizer Channel A

Function	Sine Wave (~)
Frequency	20 kHz
Amplitude	1 Vrms
Phase	0 Degrees
dc Offset	0 V
Modulation	OFF
Sweep	OFF

Frequency Synthesizer Channel B

Function	Sine Wave (~)
Frequency	26 kHz
Amplitude	1 Vrms
Phase	0 Degrees
dc Offset	0 V
Modulation	OFF
Sweep	OFF

3. Press the HP 3563A keys as follows:

[Control]
PRESET **RESET**

[Input Setup]
CAL **SINGLE
CAL**

[Input Setup] [Entry]
RANGE **2 Vrms**

[Input Setup]
**INPUT
CONFIG** **GROUND
CHAN 1**
..... **GROUND
CHAN 2**

Performance Tests
13. Intermodulation Distortion

[Measurement]
WINDOW FLAT TOP

[Measurement] [Entry]
FREQ CENTER FREQ 20 kHz

[Display]
UNITS P SPEC UNITS VOLTS RMS
..... VOLTS

[Display]
A & B

[Markers] [Entry]
X 20 kHz

- Adjust the amplitude of Frequency Synthesizer Channel A until $Y_a=0$ dBVrms 50 mdB.
- Press the HP 3563A keys as follows:

[Markers] [Entry]
X 26 kHz

- Adjust the amplitude of Frequency Synthesizer Channel B until $Y_a=0$ dBVrms 50 mdB.

Note



The amplitude of Frequency Synthesizer Channel A may change after adjusting Frequency Synthesizer Channel B. Verify the amplitude of each synthesizer before proceeding with step 7.

Table 4-14. Intermodulation Distortion Measurement One

Fundamental Frequencies		Harmonic Frequency
F1	F2	
20 kHz	26 kHz	6 kHz
20 kHz	26 kHz	14 kHz
20 kHz	26 kHz	12 kHz
20 kHz	26 kHz	8 kHz

7. Press the HP 3563A keys as follows:

```
[ Measurement ]      [ Entry ]
  AVG      .....    16      .....    ENTER
              .....    STABLE

[ Display ]          [ Entry ]
  SCALE      .....    Y FIXD      -100, .1 dB
              SCALE
```

8. For each of the harmonic frequencies listed in Table 4-14 perform steps a through c:

a. Press the HP 3563A keys as follows:

```
[ Measurement ]
  FREQ      .....    CENTER      To harmonic frequency in Table 4-14.
              FREQ

[ Control ]
  START

[ Markers ]
  X      .....    To harmonic frequency in Table 4-14.
```

- b. If the Ya marker reading is less than or equal to -80 dBVrms, check PASS on the Performance Test Record for Measurement One, Channel 1 with the BNC shell grounded.
- c. If the Yb marker reading is less than or equal to -80 dBVrms, check PASS on the Performance Test Record for Measurement One, Channel 2 with the BNC shell grounded.

Intermodulation Distortion Test Measurement Two

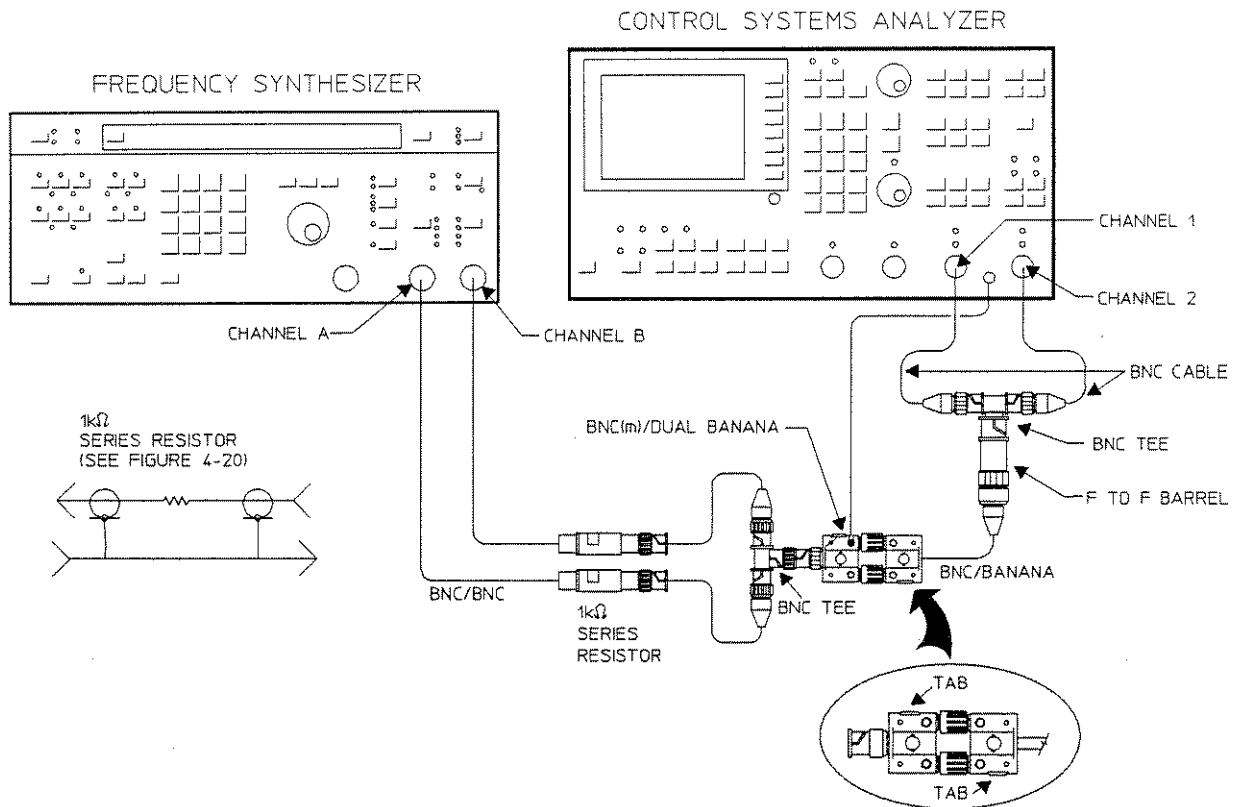

Figure 4-21. Intermodulation Distortion Test Two Setup

Note



If the "COMBINED" mode is used on the Frequency Synthesizer, output from Channel A with one 50Ω termination instead of the 1 kΩ series resistors.

Procedure

1. Connect the test instruments as shown in Figure 4-21, so the center conductor of each channel's BNC is grounded.

2. Press the HP 3563A keys as follows:

```
[ Input Setup ]
  INPUT
  CONFIG ..... FLOAT
                CHAN 1
                .....
                FLOAT
                CHAN 2
```

3. For each of the harmonic frequencies listed in Table 4-15 perform steps a through c.

Table 4-15. Intermodulation Distortion Measurement Two

Fundamental Frequencies		Harmonic Frequency
F1	F2	
20 kHz	26 kHz	6 kHz
20 kHz	26 kHz	14 kHz
20 kHz	26 kHz	12 kHz
20 kHz	26 kHz	8 kHz

a. Press the HP 3563A keys as follows:

```
[ Measurement ]
  FREQ ..... CENTER To harmonic frequency in Table 4-15.
                FREQ
```

```
[ Control ]
  START
```

```
[ Markers ]
  X ..... To harmonic frequency in Table 4-15.
```

b. If the Ya marker reading is less than or equal to -80 dBV_{rms}, check PASS on the Performance Test Record for Measurement One, Channel 1 with the BNC center conductor grounded.

c. If the Yb marker reading is less than or equal to -80 dBV_{rms}, check PASS on the Performance Test Record for Measurement One, Channel 2 with the BNC center conductor grounded.

4. Connect the test instruments as shown in Figure 4-19.

5. Change the frequency of Frequency Synthesizer Channel A to **89 kHz**.

6. Change the frequency of Frequency Synthesizer Channel B to **99 kHz**.

Performance Tests
 13. Intermodulation Distortion

7. Press the HP 3563A keys, as follows:

```
[ Measurement ]
  AVG          .....   AVG
                          OFF

[ Measurement ]           [ Entry ]
  FREQ          .....   CENTER   .....   89 kHz
                          FREQ

[ Control ]
  START

[ Markers ]           [ Entry ]
  X              .....   89 kHz
```

8. Adjust the amplitude of Frequency Synthesizer Channel A until $Y_a = 0$ dB 50 mdB.

9. Press the HP 3563A keys as follows:

```
[ Measurement ]           [ Entry ]
  FREQ          .....   CENTER   .....   99 kHz
                          FREQ

[ Markers ]           [ Entry ]
  X              .....   99 kHz
```

10. Adjust the amplitude of Frequency Synthesizer Channel B until $Y_a = 0$ dB 50 mdB.

11. Press the HP 3563A keys as follows:

```
[ Measurement ]
  AVG          .....   STABLE
```

Table 4-16. Intermodulation Distortion Measurement Two

Fundamental Frequencies		Harmonic Frequency
F1	F2	
89 kHz	99 kHz	10 kHz
89 kHz	99 kHz	79 kHz
89 kHz	99 kHz	20 kHz
89 kHz	99 kHz	69 kHz

12. For each of the harmonic frequencies listed in Table 4-16 perform steps a through c:

a. Press the HP 3563A keys as follows:

[Measurement]
 FREQ CENTER To harmonic frequency in Table 4-16.
 FREQ

[Control]
 START

[Display]
 X To harmonic frequency in Table 4-16.

- b. If the Ya marker reading is less than or equal to -80 dBVrms, check PASS on the Performance Test Record for Measurement Two, Channel 1 with the BNC shell floating.
 - c. If the Yb marker reading is less than or equal to -80 dBVrms, check PASS on the Performance Test Record for Measurement Two, Channel 2 with the BNC shell floating.
13. Connect the test instruments as shown in Figure 4-21 so the center conductor of each channel's BNC is grounded.
14. For each of the harmonic frequencies listed in Table 4-16 perform steps a through c:
- a. Press the HP 3563A keys as follows:

[Measurement]
 FREQ CENTER To harmonic frequency in Table 4-16.
 FREQ

[Control]
 START

[Markers]
 X To harmonic frequency in Table 4-16.

- b. If the Ya marker reading is less than or equal to -80 dBVrms, check PASS on the Performance Test Record for Measurement Two, Channel 1 with the BNC center conductor grounded.
- c. If the Yb marker reading is less than or equal to -80 dBVrms, check PASS on the Performance Test Record for Measurement Two, Channel 2 with the BNC center conductor grounded.

If Test Fails

If this test fails, contact your local Hewlett-Packard sales and service office or have a qualified service technician see the following sections in the *HP 3563A Service Manual*:

Adjustments
Section III

2nd Pass Gain Adjustment
ADC Offset and Reference Adjustment

Troubleshooting
Section VII

A33, A35 Input Boards
A32, A34 Analog Digital Converter Boards

14. Noise and Spurious Signal Level

This test measures the level of the noise floor and any spurious signals generated within the HP 3563A.

Specification

When the input is terminated with a 50 load, the amplitude of all spurious signals must be at least 80 dB below the range setting. When using a flat top window and a 50 load, the average noise level must be less than:

Frequency	Noise Level
20 Hz to 1 kHz	-134 dBV/ $\sqrt{\text{Hz}}$
1 kHz to 100 kHz	-144 dBV/ $\sqrt{\text{Hz}}$

Required Test Equipment

- 50 Ω feedthrough terminations (2)
- Alligator Clip Cable (2)

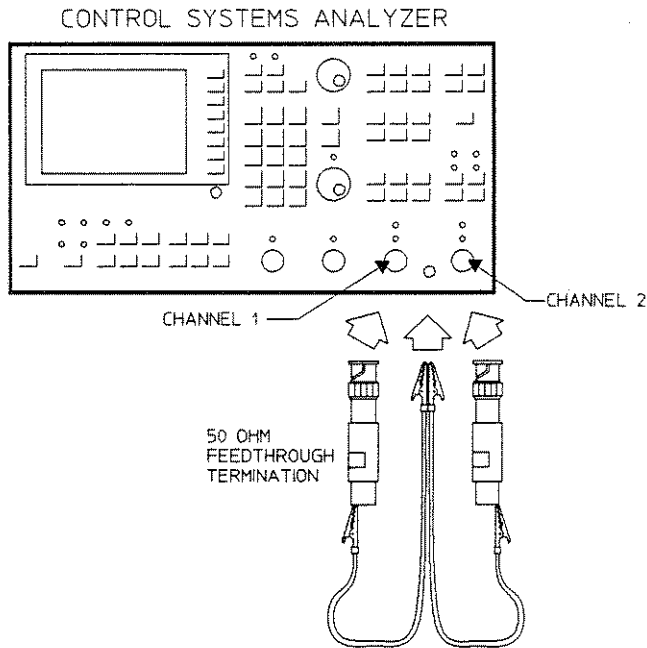

Figure 4-22. Noise and Spurious Signal Level Test Setup

Procedure

1. Connect the test instruments as shown in Figure 4-22. Keep the leads from the feedthrough terminations to chassis ground as short as possible.
2. Press the HP 3563A keys as follows:

[Control]			
PRESET	RESET	
[Input Setup]			
CAL	SINGLE	
		CAL	
[Input Setup]		[Entry]	
RANGE	-51 dBVrms	
[Input Setup]			
INPUT			
CONFIG	CHAN 1	
		AC	
	CHAN 2	
		AC	
[Measurement]			[Entry]
FREQ	FREQ
		SPAN
	START
		FREQ
			1 kHz
			20 Hz
[Measurement]		[Entry]	
AVG	20
	STABLE
			ENTER
[Measurement]			
WINDOW	UNIFRM	
		(NONE)	
[Display]			
UNITS	P SPEC
		UNITS
			VOLTS
			RMS
			VOLTS

Performance Tests

14. Noise and Spurious Signal Level

3. Press the HP 3563A keys as follows:

[Control]
START

[Display]
SCALE Y AUTO
SCALE

[Markers]
SPCL
MARKER MRKR→
PEAK

4. If the Ya marker reading is less than or equal to -131 dBVrms, check PASS on the Performance Test Record for Channel 1.

5. Press the HP 3563A keys as follows:

[Display]
B

[Display]
SCALE Y AUTO
SCALE

[Markers]
SPCL
MARKER MRKR→
PEAK

6. If the Yb marker reading is less than or equal to -131 dBVrms, check PASS on the Performance Test Record for Channel 2.

Table 4-17. Spurious Signals

Start Frequency	Frequency Span	Specification
20 Hz	1 kHz	≤ -131 dBV
1 kHz	10 kHz	≤ -131 dBV
10 kHz	10 kHz	≤ -131 dBV
20 kHz	10 kHz	≤ -131 dBV
30 kHz	10 kHz	≤ -131 dBV
40 kHz	10 kHz	≤ -131 dBV
50 kHz	10 kHz	≤ -131 dBV
60 kHz	10 kHz	≤ -131 dBV
70 kHz	10 kHz	≤ -131 dBV
80 kHz	10 kHz	≤ -131 dBV
90 kHz	10 kHz	≤ -131 dBV

7. For the rest of the start frequencies in Table 4-17 perform steps a through d:

- a. Press the HP 3563A keys as follows:

```
[ Measurement ]
  FREQ      .....  START      To start frequency in Table 4-17.
                   .....  FREQ
                   .....  FREQ      To frequency span in Table 4-17.
                   .....  SPAN
```

```
[ Display ]
  A
```

```
[ Control ]
  START
```

```
[ Markers ]
  SPCL
  MARKER .....  MRKR→
                   .....  PEAK
```

- b. If the Ya marker reading is less than or equal to -131 dBVrms, check PASS on the Performance Test Record for Channel 1.

Performance Tests

14. Noise and Spurious Signal Level

c. Press the HP 3563A keys as follows:

[Display]
B

[Markers]
SPCL
MARKER MRKR→
PEAK

d. If the Yb marker reading is less than or equal to -131 dBVrms, check PASS on the Performance Test Record for Channel 2.

Table 4-18. Noise Level

Start Frequency	Frequency Span	Specification
20 Hz	1 kHz	$\leq -134 \text{ dBV}/\sqrt{\text{Hz}}$
1 kHz	50 kHz	$\leq -144 \text{ dBV}/\sqrt{\text{Hz}}$
50 kHz	50 kHz	$\leq -144 \text{ dBV}/\sqrt{\text{Hz}}$

8. Press the HP 3563A keys as follows:

[Measurement]
WINDOW FLAT
TOP

[Display]
UNITS P SPEC
UNITS $V/\sqrt{\text{Hz}}$
 $(\sqrt{\text{PSD}})$

9. For each of the start frequencies listed in Table 4-18 perform steps a through e:

a. Press the HP 3563A keys as follows:

[Measurement]
FREQ START To start frequency in Table 4-18.
FREQ
..... FREQ To frequency span in Table 4-18.
SPAN

[Control]
START

b. When the average is complete, press the HP 3563A keys as follows:

[Display]
A

[Markers]
SPCL
MARKER MRKR→
PEAK

c. If the Ya marker reading is less than or equal to the specification, check PASS on the Performance Test Record for Channel 1.

d. Press the HP 3563A keys as follows:

[Display]
B

[Markers]
SPCL
MARKER MRKR→
PEAK

e. If the Yb marker reading is less than or equal to the specification, check PASS on the Performance Test Record for Channel 2.

If Test Fails

If this test fails, contact your local Hewlett-Packard sales and service office or have a qualified service technician see the following sections in the *HP 3563A Service Manual*:

Adjustments
Section III

2nd Pass Gain Adjustment
ADC Offset and Reference Adjustment

Troubleshooting
Section VII

A33, A35 Input Boards
A32, A34 Analog Digital Converter
A5 Digital Filter
A4 Local Oscillator

15. Cross Talk

The cross talk test measures the amount of energy in one channel that has been coupled across from the other channel. This is accomplished by placing a high signal level on one channel and then measuring the relative signal amplitude on the other channel.

Specification

When a 50Ω termination is used, the cross talk between channels will be at least 140 dB below the input signal level.

Required Test Equipment

- Frequency Synthesizer
- 50Ω feedthrough termination
- Alligator/Alligator Clip
- BNC Cable

Cross Talk Channel 1 Test

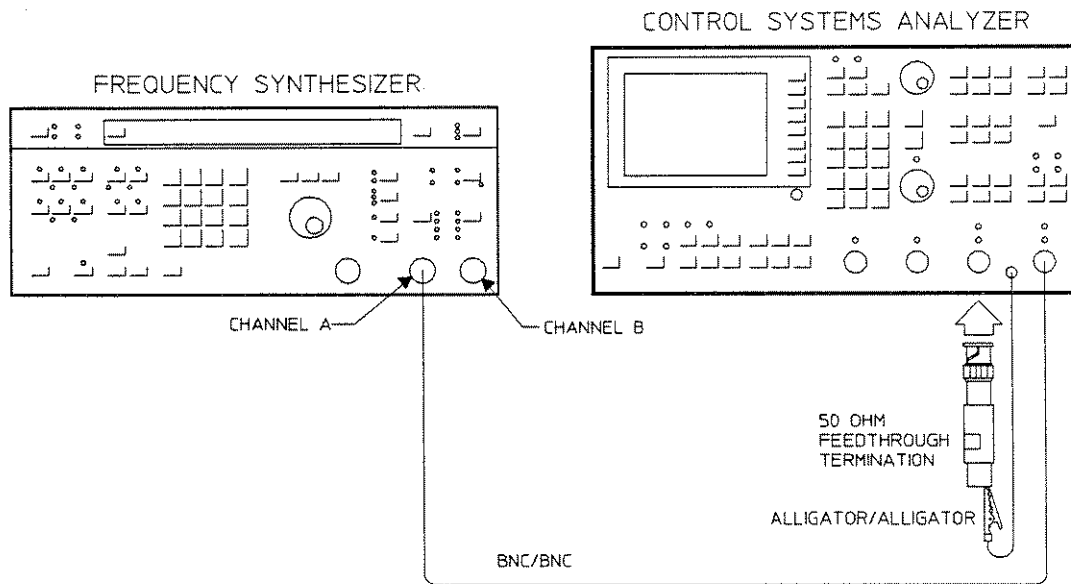

Figure 4-23. Cross Talk Channel 1 Test Setup

Procedure

1. Connect the test instruments as shown in Figure 4-23.
2. Set the Frequency Synthesizer as follows:

Function	Sine Wave (~)
Frequency	99 kHz
Amplitude	14 Vrms
High Voltage Output	ON
Phase	0 Degrees
dc Offset	0 V
Modulation	OFF
Sweep	OFF

3. Press the HP 3563A keys as follows:

[Control]
PRESET RESET

[Input Setup]
CAL SINGLE CAL

[Measurement] [Entry]
FREQ 99 kHz
CENTER FREQ

[Measurement]
WINDOW FLAT TOP

[Measurement] [Entry]
AVG 16 ENTER
STABLE

[Input Setup]
RANGE AUTO 1 AUTO 2
UP & DWN UP & DWN

Performance Tests

15. Cross Talk

[Control]
START

[Display]
A & B

[Markers] [Entry]
X 99 kHz

[Display] [Entry]
SCALE Y FIXD -140, 30 dB
 SCALE

[Display]
B

[Markers]
Y

4. Using the marker knob, move the Y marker to the center of the X marker dot and press the HP 3563A keys as follows:

..... HOLD Y
 UPPER

[Display]
A

5. Using the marker knob, move the Y marker to the center of the X marker dot.
6. If the delta Y is greater than or equal to 140 dB, check PASS on the Performance Test Record for Channel 1.

Cross Talk Channel 2 Test

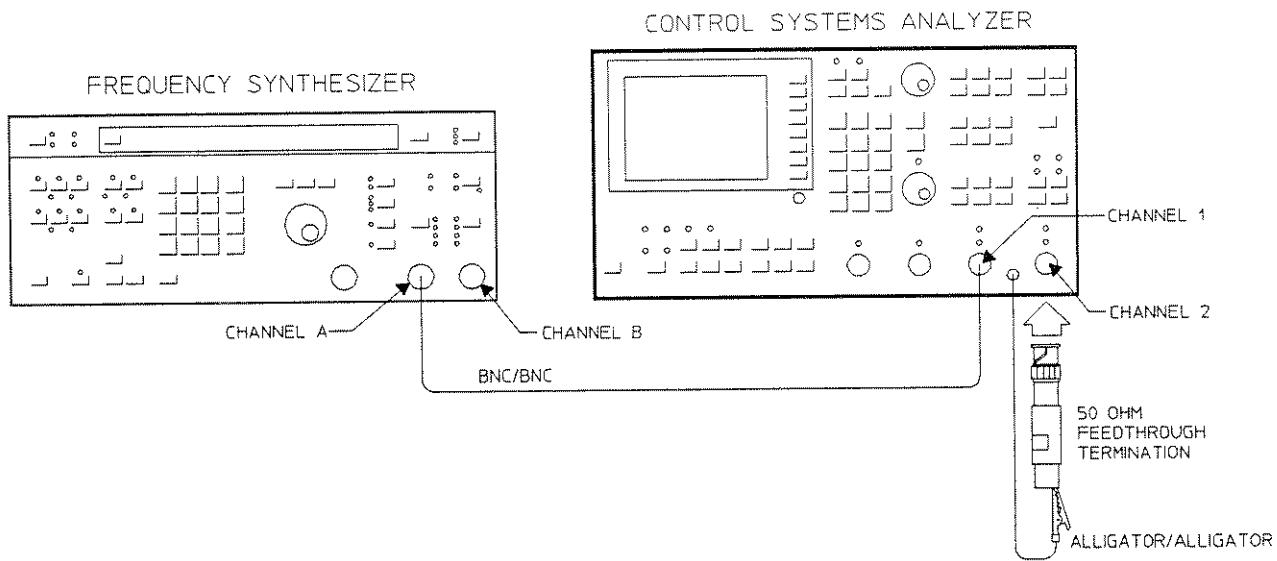

Figure 4-24. Cross Talk Channel 2 Test

Procedure

1. Connect the test instruments as shown in Figure 4-24.
2. Press the HP 3563A keys as follows:

[Markers]
Y
OFF

[Control]
START

[Display]
A&B

[Markers] [Entry]
X 99 kHz

[Display]
A

[Markers]
Y

Performance Tests

15. Cross Talk

- Using the marker knob, move the Y marker to the center of the X marker dot and press the HP 3563A keys as follows:

..... HOLD Y
UPPER

[Display]
B

- Using the marker knob, move the Y marker to the center of the X marker dot.
- If the delta Y is greater than or equal to 140 dB, check PASS on the Performance Test Record for Channel 2.

If Test Fails

If this test fails, contact your local Hewlett-Packard sales and service office or have a qualified service technician see the following sections in the *HP 3563A Service Manual*:

Adjustments

None

Troubleshooting
Section VIII

A33, A35 Input Boards

16. Common Mode Rejection

This test measures the capability of the HP 3563A to ignore a signal which appears simultaneously and in phase at the high and low input of a single channel.

Specification

When a common mode signal is input to a single channel, the relative value compared to the amplitude of the input single will be:

Frequency	Specification
0 Hz to 66 Hz	80 dB
66 Hz to 500 Hz	65 dB

Required Test Equipment

- Frequency Synthesizer
- Common Mode Cable
- BNC Tee
- Female to Female Barrel
- Alligator/Alligator Cable
- BNC to BNC: length \leq 30 cm (2)
- BNC Cable

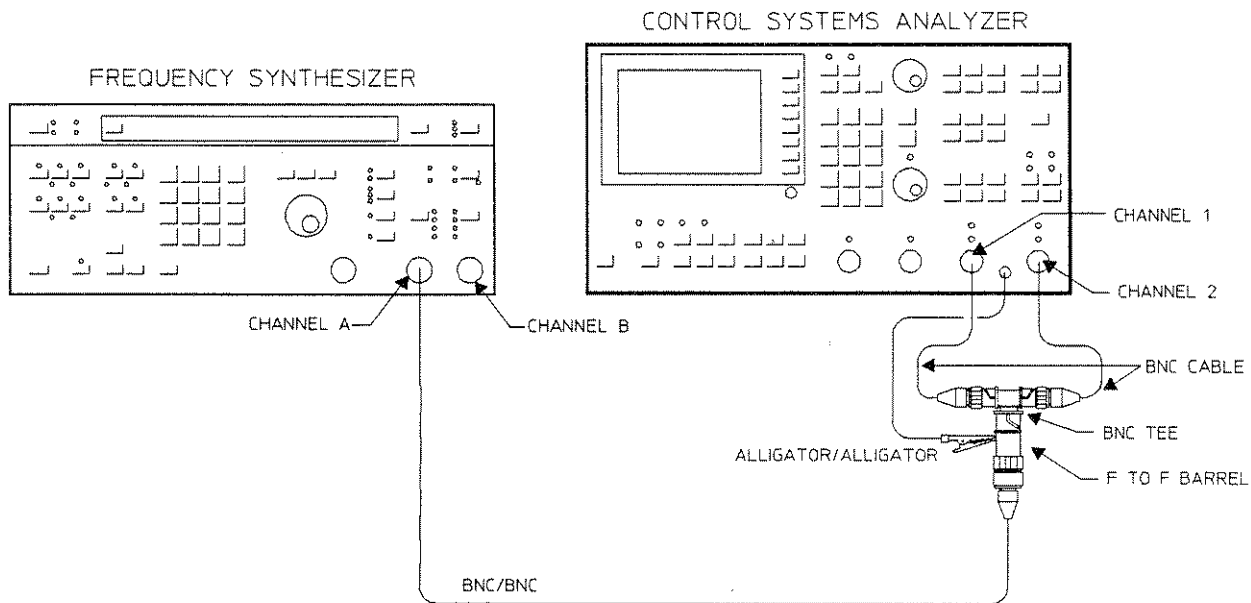

Figure 4-25. Common Mode Rejection Test Setup One

Procedure

1. Connect the test instruments as shown in Figure 4-25.
2. Set the Frequency Synthesizer as follows:

Function	Sine Wave (~)
Frequency	1 kHz
Amplitude	1 mVrms
Phase	0 Degrees
Modulation	Off
Sweep	Off

3. Press the HP 3563A keys as follows:

[Control]			
PRESET	RESET	
[Input Setup]			
CAL	SINGLE CAL	
		CAL	
[Measurement]		[Entry]	
AVG	16 ENTER
		STABLE	
[Measurement]			
WINDOW	FLAT TOP	
[Display]			
A & B			
[Display]			
UNITS	P SPEC UNITS VOLTS RMS
[Input Setup]			
RANGE	AUTO 1 UP&DWN AUTO 2 UP&DWN

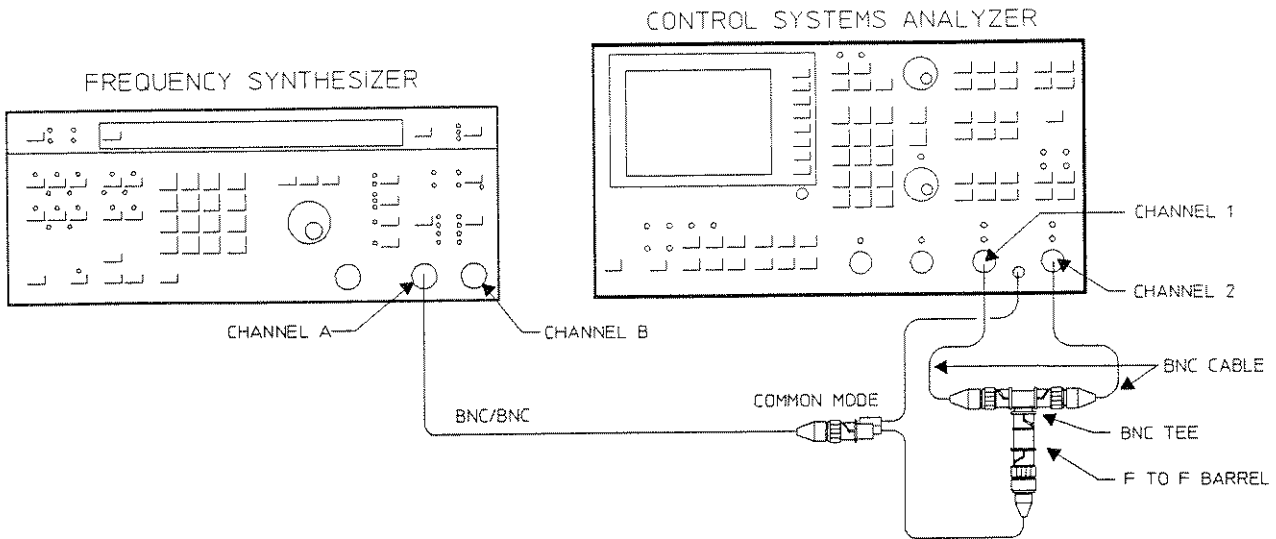

Figure 4-26. Common Mode Rejection Test Setup Two

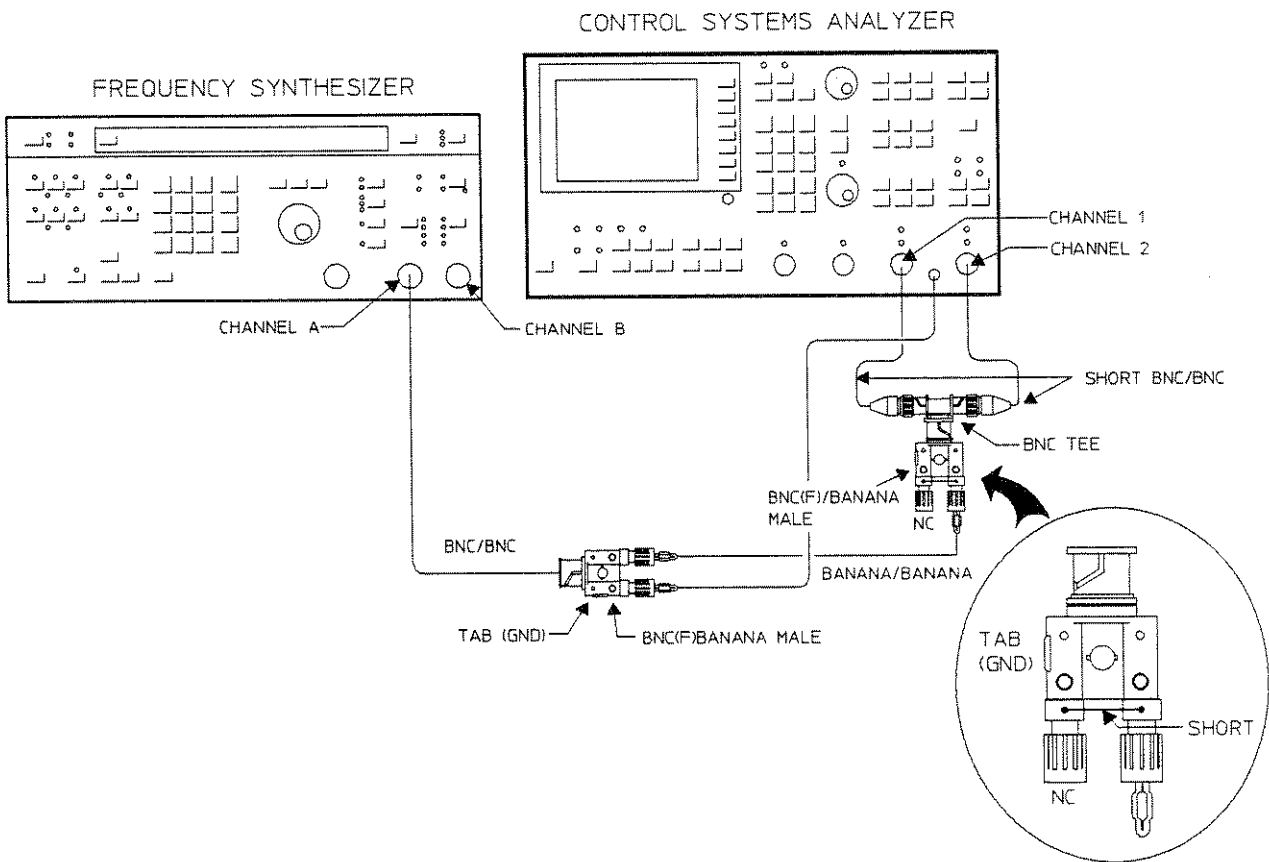

Figure 4-27. Alternate Common Mode Rejection Test Setup Two

Table 4-19. Common Mode Rejection

Signal Amplitude	Signal Frequency	Specification
3.536 Vrms	66 Hz	≥ 80 dB
3.536 Vrms	500 Hz	≥ 65 dB

4. For each of the frequencies listed in Table 4-19 connect the test instruments as shown in Figure 4-25 and perform steps a through d:

a. Set the Frequency Synthesizer as follows:

Amplitude To signal amplitude in Table 4-19
 Frequency To signal frequency in Table 4-19

b. Press the HP 3563A keys as follows:

[Measurement]
FREQ CENTER FREQ To signal frequency in Table 4-19.

[Control]
START

[Markers]
SPCL
MARKER MRKR →
 PEAK

c. Record the Ya marker amplitude reading on the Performance Test Record as the first measurement for Channel 1.

d. Record the Yb marker amplitude reading on the Performance Test Record as the first measurement for Channel 2.

5. Connect the test instruments as shown in Figure 4-26 or Figure 4-27. For each of the frequencies listed in Table 4-19, perform steps a through c.

a. Press the HP 3563A keys as follows:

[Control]
START

[Display]
SCALE Y AUTO
 SCALE

[Markers]
X To signal frequency in Table 4-19.

- b. When the average is complete, record the Ya amplitude reading on the Performance Test Record as the second measurement for Channel 1.
 - c. Record the Yb amplitude reading on the Performance Test Record as the second measurement for Channel 2.
6. Calculate the relative value for both channels:

$$\text{First Measurement} - \text{Second Measurement} = \text{Relative Value}$$

If Test Fails

If this test fails, contact your local Hewlett-Packard sales and service office or have a qualified service technician see the following sections in the *HP 3563A* Service Manual:

Adjustments
Section III

Input dc Offset Adjustment
Calibrator Adjustment

Troubleshooting
Section VII

A33, A35 Input Boards
A30 Analog Source

17. External Reference Test

This test determines if the external reference input will lock on to an external signal that is within the specified range.

Specification

The HP 3563A will lock to external signals of 1, 2, 5, and 10 MHz $\pm 0.01\%$. The amplitude of the signal must be between 0 dBm and +20 dBm.

Required Test Equipment

Frequency Synthesizer
BNC Cable

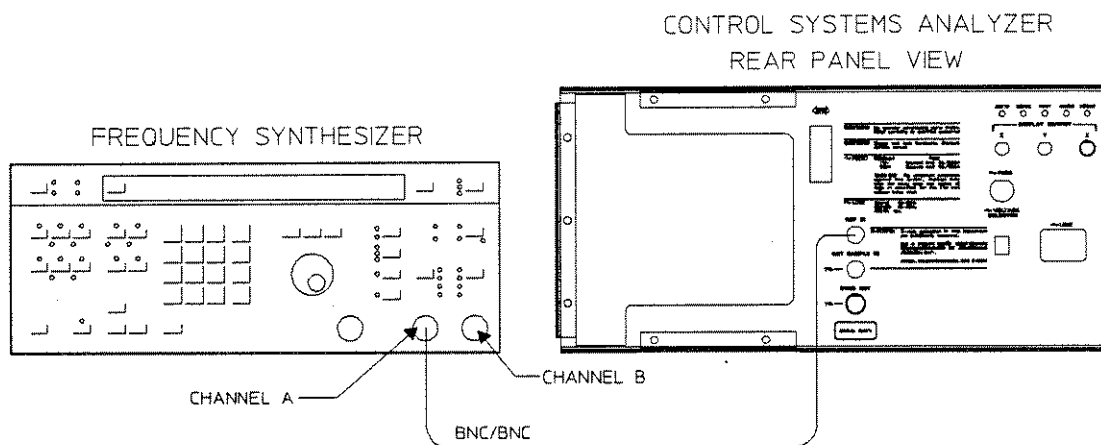

Figure 4-28. External Reference Test Setup

Procedure

1. Connect the HP 3563A as shown in Figure 4-28.

2. Set Frequency Synthesizer as follows:

Function	Sine Wave (~)
Frequency	1.000 MHz
Amplitude	0 dBm
Phase	0 Degrees
dc Offset	0 V
Modulation	OFF
Sweep	OFF

3. Press the HP 3563A keys as follows:

[Control]
PRESET RESET

[Input Setup]
CAL SINGLE
CAL

4. Slowly decrease the frequency in 100 Hz steps on the Frequency Synthesizer until the “**EXT Reference Not Locked**” message is displayed.

5. Record the frequency value on the Performance Test Record.

6. Change the Frequency on the Frequency Synthesizer to **10.000 MHz**.

7. On the HP 3563A press:

[Control]
PRESET

8. Slowly increase the frequency in 1 kHz step on the Frequency Synthesizer until the “**EXT Reference Not Locked**” message is displayed.

9. Record the frequency value on the Performance Test Record.

If Test Fails

If this test fails, contact your local Hewlett-Packard sales and service office or have a qualified service technician see the following sections in the *HP 3563A Service Manual*:

Adjustments 20.48 MHz Reference Adjustment
Section III

Troubleshooting A31 Trigger Board
Section VIII

18. Source Residual Offset

This test measures the level of residual offset generated by the source at the 0V offset setting.

Specification

The source residual offset will be no more than 10 mV at the 0V offset setting.

Required Test Equipment

Digital Voltmeter
BNC/Dual Banana Cable

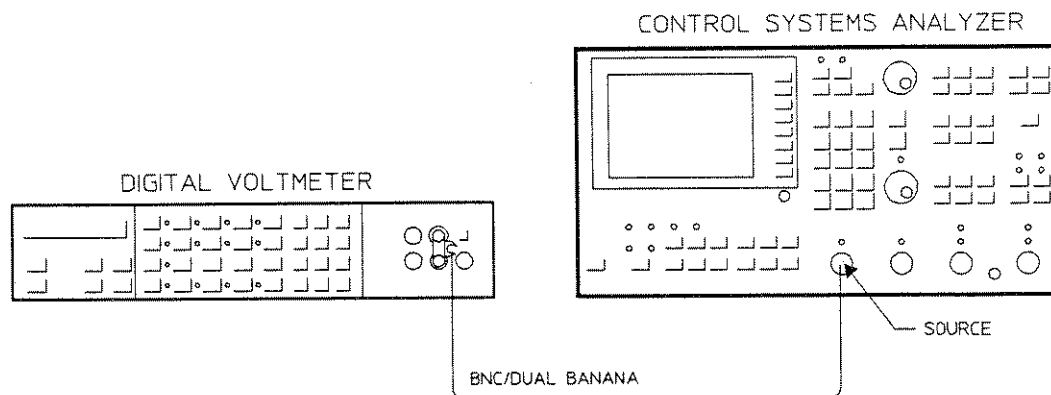

Figure 4-29. Source Residual Offset Test Setup

Procedure

1. Connect the test instruments as shown in Figure 4-29.
2. Set the digital voltmeter as follows:

Function	dc (==== V)
Range	Auto
Trigger	Internal
Sample Rate	Maximum
High Resolution	ON
Auto Cal	ON

3. Press the HP 3563A keys as follows:

[Control]				
PRESET	RESET		
[Input Setup]				
CAL	SINGLE		
		CAL		
[Measurement]			[Entry]	
SOURCE	SOURCE	1 V
		LEVEL		
	SOURCE	FIXED
		TYPE		SINE
[Entry]				
100 kHz				

4. Record the digital voltmeter reading on the Performance Test Record for the 1V setting.

5. Press the HP 3563A keys as follows:

[Measurement]			[Entry]	
SOURCE	SOURCE	5 V
		LEVEL		

6. Record the digital voltmeter reading on the Performance Test Record for the 5V setting.

If Test Fails

If this test fails, contact your local Hewlett-Packard sales and service office or have a qualified service technician see the following sections in the *HP 3563A Service Manual*:

Adjustments

None

Troubleshooting
Section VIII

A30 Analog Source Board

19. Source Amplitude Accuracy and Flatness

This test measures the amplitude accuracy and flatness of the HP 3563A Source.

Specification

The amplitude reading will not deviate from the source amplitude setting by more than 1 dB (12.2%) when terminated into 1M for frequencies between 0 Hz and 65 kHz, and +1 dB, -1.5 dB for frequencies between 65 kHz and 100 kHz.

Procedure

1. Connect the HP 3563A Source to Channel 1.
2. Press the HP 3563A keys as follows:

```
[ Control ]
  PRESET      .....   RESET

[ Input Setup ]
  CAL         .....   SINGLE
                           CAL

[ Input Setup ]
  INPUT
  CONFIG      .....   GROUND
                           CHAN 1

[ Input Setup ]      [ Entry ]
  RANGE          .....   5 V

[ Measurement ]
  MEAS
  MODE          .....   SWEPT      .....   LINEAR
                           SINE          SWEEP

[ Measurement ]
  SOURCE        .....   SOURCE
                           TYPE          ON
                           .....
                           SOURCE
                           LEVEL          [ Entry ]
                                           4.47 V

[ Display ]
  UNITS        .....   P SPEC      .....   VOLTS
                           UNITS          RMS
                                           .....
                                           VOLTS
```

19. Source Amplitude Accuracy and Flatness

[Measurement] [Entry]
 FREQ STOP FREQ 65 kHz

[Control]
 START

3. When the sweep is complete, press the HP 3563A keys as follows:

[Display] [Entry]
 SCALE Y FIXD SCALE 9, 11 dB

4. If the trace is between the 9 dB and the 11 dB limits, check PASS on the Performance Test Record for the 0 to 65 kHz span.

5. Press the HP 3563A keys as follows:

[Measurement] [Entry]
 FREQ START FREQ 65 kHz

[Control]
 START

6. When the sweep is complete, press the HP 3563A keys as follows:

[Display] [Entry]
 SCALE Y FIXD SCALE 8.5, 11 dB

7. If the trace is between the 8.5 dB and the 11 dB limits, check PASS on the Performance Test Record for the 65 kHz to 100 kHz span.

If Test Fails

If this test fails, contact your local Hewlett-Packard sales and service office or have a qualified service technician see the following sections in the *HP 3563A Service Manual*:

Troubleshooting
 Section VIII

A30 Analog Source Board

20. Source Distortion

This test measures the level of any spurious signals generated by the HP 3563A Source.

Specification

When the source is set between dc and 10 kHz, the distortion will be at least 60 dB below the signal level. When the source is set between 10 kHz and 100 kHz, the distortion will be at least 40 dB below the signal level.

Required Test Equipment

BNC Cable

Procedure

1. Connect the HP 3563A Source to Channel 1.
2. Press the HP 3563A keys as follows:

[Control]			
PRESET	RESET	
[Input Setup]			
CAL	SINGLE CAL	
[Input Setup]			
INPUT CONFIG	CHAN 1 AC	
	GROUND CHAN 1	
[Measurement]			
WINDOW	FLAT TOP	
[Measurement]		[Entry]	
AVG	4 ENTER
	STABLE	
[Display]			[Entry]
SCALE	X FIXD SCALE375,100 kHz

Table 4-20. Source Distortion

Range Setting	Source Amplitude	Source Frequency	Delta Y Value
25 mVpk	25 mVpk	10 kHz	60 dB
5 Vpk	5 Vpk	10 kHz	60 dB
25 mVpk	25 mVpk	99 kHz	40 dB
5 Vpk	5 Vpk	99 kHz	40 dB

3. For each of the range settings listed in Table 4-20 perform steps a through e:

a. Press the HP 3563A keys as follows:

[Markers]
Y OFF

[Input Setup]
RANGE To range setting in Table 4-20.

[Measurement]
SOURCE SOURCE LEVEL To source amplitude in Table 4-20.
..... SOURCE TYPE FIXED SINE
..... To source frequency in Table 4-20.

[Control]
START

[Display]
SCALE Y AUTO SCALE
SPCL
MARKER MRKR→
PEAK

[Markers]
Y

b. Using the marker knob, move the Y marker to the center of the X marker dot.

21. Source Energy Measurement

This test measures the in-band energy of the HP 3563A noise source using the power marker function of the HP 3563A and a true rms voltmeter.

Specification

The percentage in-band energy of the random noise will be at least 70%. The percentage in-band energy of the chirp will be at least 85%.

Required Test Equipment

Digital Voltmeter
BNC Tee
BNC/Dual Banana

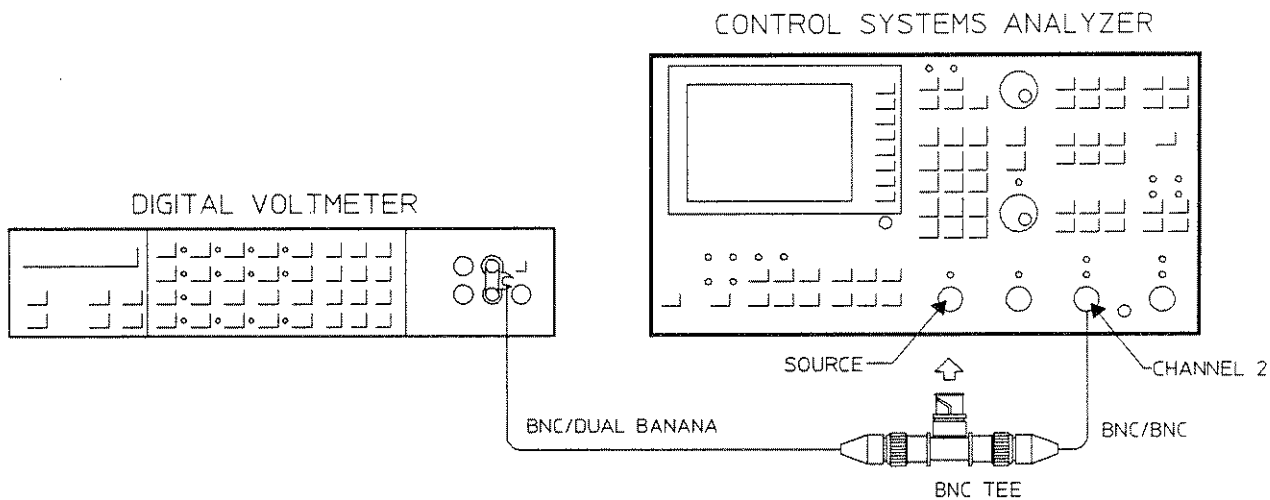

Figure 4-30. Source Energy Measurement Test Setup

Performance Tests
21. Source Energy Measurement

Procedure

1. Connect the test instruments as shown in Figure 4-30.
2. Set the test instruments initially as follows:

Digital Voltmeter
Function **ac V (~V)**
Trigger **Internal**

3. Press the HP 3563A keys as follows:

[Control]
PRESET **RESET**

[Input Setup]
CAL **SINGLE
CAL**

[Input Setup]
**INPUT
CONFIG** **GROUND
CHAN 1**

[Measurement]
WINDOW **UNIFORM
(NONE)**

[Input Setup]
RANGE **AUTO 1
UP&DWN**

[Measurement] [Entry]
SOURCE **SOURCE** **1 Vrms**
LEVEL

[Measurement] [Entry]
FREQ **FREQ** **1 kHz**
SPAN
..... **CENTER** **5 kHz**
FREQ

[Measurement]	[Entry]		
AVG 160	ENTER
	STABLE	
[Control]			
START			
[Display]			
SCALE	Y AUTO	
		SCALE	

Note  Wait until the measurement is finished before pressing POWER. The X & Y markers must be off.

[Display]				
UNITS	P SPEC	VOLTS
		UNITS		RMS
			VOLTS
[Display]				
COORD	MAG		
		(LIN)		

Note  Wait for the measurement to finish before proceeding.

[Markers]				
SPCL	MARKER	POWER
MARKER		CALC		

Note  X and Y markers must be off.

Performance Tests

21. Source Energy Measurement

4. Take at least 160 averages by pressing the Digital Voltmeter keys as follows:

MATH
2
RDGS
STORE

5. After the "RDGS STORE" annunciator turns off, press the Digital Voltmeter keys as follows:

HOLD
RDGS
STORE
RECALL
0

6. Record the voltmeter average on the Performance Test Record.

7. Record the HP 3563A power measurement on the Performance Test Record.

8. Press the HP 3563A keys as follows:

[Measurement]
SOURCE PRIODC
CHIRP

[Input Setup]
SELECT SOURCE
TRIG TRIG

[Control]
START

Note

Wait for the measurement to finish before proceeding.



[Markers]
SPCL MARKER POWER
MARKER CALC

9. Take at least 160 averages by pressing the Digital Voltmeter keys as follows:

MATH
2
RDGS
STORE

10. After the "RDGS STORE" annunciator turns off, press the Digital Voltmeter keys as follows:

HOLD
RDGS
STORE
RECALL
0

11. Record the voltmeter average on the Performance Test Record.

12. Record the HP 3563A power measurement on the Performance Test Record.

13. The percentage in-band energy for random noise and chirp are calculated using the following formula:

$$\sqrt{\frac{\text{HP3563A Reading}}{\text{Voltmeter Reading}}} \times 100 = \text{Percentage In-Band Energy}$$

If Test Fails Check:

If this test fails, contact your local Hewlett-Packard sales and service office or have a qualified service technician see the following sections in the *HP 3563A Service Manual*:

Adjustments

None

Troubleshooting
Section VII

A30 Analog Source Board
A1 Digital Source Board
A4 Local Oscillator Board

Performance Test Record

HP 3563 A Control Systems Analyzer

Calibration Entity: _____
Address: _____
Serial No. _____ Test by: _____
Customer _____ Report/Order No. _____
Temperature Range _____ Test Date: _____
Relative Humidity _____ Power Line Frequency _____
Installed Options _____

Instruments Used:

AC Calibrator _____ Model _____
_____ Serial No. _____
Traceability No. _____ Cal Due Date _____

Frequency Synthesizer _____ Model _____
_____ Serial No. _____
Traceability No. _____ Cal Due Date _____

Digital Voltmeter _____ Model _____
_____ Serial No. _____
Traceability No. _____ Cal Due Date _____

Other _____

Other _____

Optional Comments _____

This Test Record Form may be reproduced without written permission of Hewlett-Packard

1. Self Test	PASS
---------------------	-------------

2. DC Offset			
Range Setting	Measured Value		Specification
	CHANNEL 1	CHANNEL 2	
7 dBV			< -23 dBV
-35 dBV			< -65 dBV
-51 dBV			< -71 dBV

3. Amplitude Accuracy and Flatness Measurement One					
BNC shell grounded					
Range Setting	Signal Frequency	Specification		Measured Value	
		Lower Limit	Upper Limit	CHANNEL 1	CHANNEL 2
9 dBV	1 kHz	8.849 dBV	9.151 dBV		
9 dBV	99 kHz	8.849 dBV	9.151 dBV		
-13 dBV	1 kHz	-13.15 dBV	-12.85 dBV		
-13 dBV	50 kHz	-13.15 dBV	-12.85 dBV		
-13 dBV	90 kHz	-13.15 dBV	-12.85 dBV		
-13 dBV	99 kHz	-13.15 dBV	-12.85 dBV		
-23 dBV	1 kHz	-23.15 dBV	-22.85 dBV		
-23 dBV	99 kHz	-23.15 dBV	-22.85 dBV		
-26 dBV	1 kHz	-26.15 dBV	-25.85 dBV		
-21 dBV	1 kHz	-21.15 dBV	-20.85 dBV		
-17 dBV	1 kHz	-17.15 dBV	-16.85 dBV		
-14 dBV	1 kHz	-14.15 dBV	-13.85 dBV		
-11 dBV	1 kHz	-11.15 dBV	-10.85 dBV		

Amplitude Accuracy and Flatness Measurement Two					
BNC shell grounded					
Range Setting	Signal Frequency	Specification		Measured Value	
		Lower Limit	Upper Limit	CHANNEL 1	CHANNEL 2
51 dBV	1 kHz	-51.25 dBV	-50.75 dBV		
-49 dBV	1 kHz	-49.25 dBV	-48.75 dBV		
-47 dBV	1 kHz	-47.25 dBV	-46.75 dBV		
-45 dBV	1 kHz	-45.25 dBV	-44.75 dBV		
-43 dBV	1 kHz	-43.25 dBV	-42.75 dBV		
-41 dBV	1 kHz	-41.25 dBV	-40.75 dBV		
-39 dBV	1 kHz	-39.25 dBV	-38.75 dBV		

Amplitude Accuracy and Flatness Measurement Three					
BNC center conductor grounded					
Range Setting	Signal Frequency	Specification		Measured Value	
		Lower Limit	Upper Limit	CHANNEL 1	CHANNEL 2
8 dBV	1 kHz	7.499 dBV	8.501 dBV		
8 dBV	99 kHz	7.499 dBV	8.501 dBV		
-11 dBV	1 kHz	-11.50 dBV	-10.50 dBV		
-13 dBV	1 kHz	-13.50 dBV	-12.50 dBV		
-13 dBV	50 kHz	-13.50 dBV	-12.50 dBV		
-13 dBV	90 kHz	-13.50 dBV	-12.50 dBV		
-13 dBV	99 kHz	-13.50 dBV	-12.50 dBV		
-27 dBV	1 kHz	-27.50 dBV	-26.50 dBV		
-27 dBV	99 kHz	-27.50 dBV	-26.50 dBV		

4. Amplitude Linearity				
Signal Frequency = 10 kHz		Range Setting = 10 Vrms		
BNC shell grounded				
Amplitude	Specification		Measured Value	
	Upper Limit	Lower Limit	CHANNEL 1	CHANNEL 2
10.00 Vrms	10.18 Vrms	9.827 Vrms		
1.000 Vrms	1.019 Vrms	981.4 mVrms		
100.0 mVrms	103.2 mVrms	96.79 mVrms		
10.00 mVrms	11.67 mVrms	8.329 mVrms		
3.1623 mVrms	4.717 mVrms	1.608 mVrms		
1.000 mVrms	2.517 mVrms	-517.1 μ Vrms		
BNC center conductor grounded				
Amplitude	Specification		Measured Value	
	Upper Limit	Lower Limit	CHANNEL 1	CHANNEL 2
10.00 Vrms	10.59 Vrms	9.439 Vrms		
1.000 Vrms	1.061 Vrms	942.6 mVrms		
100.0 mVrms	1074 mVrms	92.91 mVrms		
10.00 mVrms	12.09 mVrms	7.941 mVrms		
3.1623 mVrms	4.850 mVrms	1.485 mVrms		
1.000 mVrms	2.559 mVrms	-555.9 μ Vrms		

5. Amplitude and Phase Match						
BNC shell grounded						
Range Setting	Part	PASS	Amplitude Specification	Part	PASS	Phase Specification
-47 dBV	1		± 0.1 dB	4		$\pm 0.5^\circ$
0 dBV	2		± 0.1 dB	5		$\pm 0.5^\circ$
10 dBV	3		± 0.1 dB	6		$\pm 0.5^\circ$
BNC center conductor grounded						
Range Setting	Part	PASS	Amplitude Specification	Part	PASS	Phase Specification
-13 dBV	7		± 0.8 dB	9		$\pm 8.5^\circ$
8 dBV	8		± 0.8 dB	10		$\pm 8.8^\circ$

6. Anti-Alias Filter Response				
Signal Frequency	Alias Frequency	PASS		Specification
		CHANNEL 1	CHANNEL 2	
156 kHz	100 kHz			≤ -80 dB
184 kHz	72 kHz			≤ -80 dB
206 kHz	50 kHz			≤ -80 dB
267 kHz	11 kHz			≤ -80 dB

7. Frequency Accuracy			
Signal Frequency	Specification		Measured Value
	Lower Limit	Upper Limit	
99,000 Hz	98.996 kHz	99.004 kHz	

8. Input Coupling Insertion Loss			
CHANNEL 1		CHANNEL 2	
Insertion Loss	Specification	Insertion Loss	Specification
	< 3 dB		< 3 dB

9. Single Channel Phase Accuracy						
BNC shell grounded						
Signal Frequency	Trigger		Specification		Measured Value	
	Slope	Type	Lower Limit	Upper Limit	CHANNEL 1	CHANNEL 2
9 kHz	POS	CHANNEL 1	-92.5°	-87.5°		
9 kHz	POS	CHANNEL 2	-92.5°	-87.5°		
9 kHz	POS	EXT	-92.5°	-87.5°		
9 kHz	NEG	EXT	87.5°	92.5°		
99 kHz	POS	CHANNEL 1	-102°	-78.0°		
99 kHz	POS	CHANNEL 2	-102°	-78.0°		
99 kHz	POS	EXT	-102°	-78.0°		
BNC center conductor grounded						
Signal Frequency	Trigger		Specification		Measured Value	
	Slope	Type	Lower Limit	Upper Limit	CHANNEL 1	CHANNEL 2
9 kHz	POS	CHANNEL 1	-96.5°	-83.5°		
9 kHz	POS	CHANNEL 2	-96.5°	-83.5°		
9 kHz	POS	EXT	83.5°	96.5°		
9 kHz	NEG	EXT	-96.5°	-83.5°		
99 kHz	POS	CHANNEL 1	-106°	-74.0°		
99 kHz	POS	CHANNEL 2	-106°	-74.0°		
99 kHz	POS	EXT	74°	106°		

10. Digital Input/Output		
Digital Internal Path		PASS
External Pod 1	Src Clk Connection Dig Pod 1 Zeros Dig Pod 1 Ones	
External Pod 2	Src Clk Connection Dig Pod 2 Zeros Dig Pod 1 Ones	
Qualifier Pod	Dig Qualifier Zeros Dig Qualifier Ones	
Arbitrary Source	Address Pre-Scaler Zeros Ones	

11. Input Impedance				
Resistance Measurement				
Range Setting	Specification		Measured Value	
	Lower Limit	Upper Limit	CHANNEL 1	CHANNEL 2
20 dBV	950 kΩ	1050 kΩ		
0 dBV	950 kΩ	1050 kΩ		
-13 dBV	950 kΩ	1050 kΩ		
Capacitance Measurement				
Channel 1			Channel 2	
Vc =	Vrms	Vc =	Vrms	
Vin =	Vrms	Vin =	Vrms	
$C = 15.92 \times 10^{-12} \sqrt{\frac{V_{in}^2}{V_c^2} - 1.210}$				
Measured Value				Specification
Channel 1		Channel 2		< 100pF
pF		pF		

12. Harmonic Distortion			
Measurement One			
Signal Frequency	Measured Value Harmonic Frequency Amplitude		Specification
	Channel 1	Channel 2	
49500 Hz			≤ -80 dB
33000 Hz			≤ -80 dB
245750 Hz			≤ -80 dB
19800 Hz			≤ -80 dB
Measurement Two			
Signal Frequency	Measured Value Harmonic Frequency Amplitude		Specification
	Channel 1	Channel 2	
49500 Hz			≤ -80 dB
33000 Hz			≤ -80 dB
24750 Hz			≤ -80 dB
19800 Hz			≤ -80 dB

13. Intermodulation Distortion Measurement One				
BNC shell grounded				
Harmonic Frequency	Channel 1		Channel 2	
	PASS	Specification	PASS	Specification
6 kHz		≤ -80 dB		≤ -80 dB
14 kHz		≤ -80 dB		≤ -80 dB
12 kHz		≤ -80 dB		≤ -80 dB
8 kHz		≤ -80 dB		≤ -80 dB
BNC center conductor grounded				
Harmonic Frequency	Channel 1		Channel 2	
	PASS	Specification	PASS	Specification
6 kHz		≤ -80 dB		≤ -80 dB
14 kHz		≤ -80 dB		≤ -80 dB
12 kHz		≤ -80 dB		≤ -80 dB
		≤ -80 dB		≤ -80 dB

Intermodulation Distortion Measurement Two				
BNC shell floating				
Harmonic Frequency	Channel 1		Channel 2	
	PASS	Specification	PASS	Specification
10 kHz		≤ -80 dB		≤ -80 dB
79 kHz		≤ -80 dB		≤ -80 dB
20 kHz		≤ -80 dB		≤ -80 dB
69 kHz		≤ -80 dB		≤ -80 dB
BNC center conductor grounded				
Harmonic Frequency	Channel 1		Channel 2	
	PASS	Specification	PASS	Specification
10 kHz		≤ -80 dB		≤ -80 dB
79 kHz		≤ -80 dB		≤ -80 dB
20 kHz		≤ -80 dB		≤ -80 dB
69 kHz		≤ -80 dB		≤ -80 dB

14. Noise and Spurious Signal Level				
Spurious Signals				
Start Frequency	Frequency Span	PASS		Specification
		CHANNEL 1	CHANNEL 2	
20 Hz	1 kHz			≤ -131 dBV
1 kHz	10 kHz			≤ -131 dBV
10 kHz	10 kHz			≤ -131 dBV
20 kHz	10 kHz			≤ -131 dBV
30 kHz	10 kHz			≤ -131 dBV
40 kHz	10 kHz			≤ -131 dBV
50 kHz	10 kHz			≤ -131 dBV
60 kHz	10 kHz			≤ -131 dBV
70 kHz	10 kHz			≤ -131 dBV
80 kHz	10 kHz			≤ -131 dBV
90 kHz	10 kHz			≤ -131 dBV
Noise Level				
Start Frequency	Frequency Span	PASS		Specification
		CHANNEL 1	CHANNEL 2	
20 Hz	1 kHz			≤ -134 dBV/√Hz
1 kHz	50 kHz			≤ -144 dBV/√Hz
50 kHz	50 kHz			≤ -144 dBV/√Hz

15. Cross Talk		
PASS		Specification
Channel 1	Channel 2	
		≥ 140 dB

16. Common Mode Rejection				
First Measurement – Second Measurement = Relative Value				
Signal Frequency	CHANNEL 1			Specification
	First Measurement	Second Measurement	Relative Value	
66 Hz				≥ 80 dB
500 Hz				≥ 65 dB
Signal Frequency	CHANNEL 2			Specification
	First Measurement	Second Measurement	Relative Value	
66 Hz				≥ 80 dB
500 Hz				≥ 65 dB

17. External Reference Test		
Frequency	Measured Value	Specification
1 MHz		< 999.90 kHz
10 MHz		> 910.001 MHz

18. Source Residual Offset			
Voltage Range Setting	Specification		Measured Value
	Lower Limit	Upper Limit	
1 Vpk	- 10 mVpk	10 mVpk	
5 Vpk	- 10 mVpk	10 mVpk	

19. Source Amplitude Accuracy and Flatness	
0 Hz to 65 kHz	PASS
65 kHz to 100 kHz	PASS

20. Source Distortion			
Source Amplitude	Source Frequency	PASS	Specification
25 mVpk	10 kHz		≥ 60 dB
5 Vpk	10 kHz		≥ 60 dB
25 mVpk	99 kHz		≥ 40 dB
5 Vpk	99 kHz		≥ 40 dB

21. Source Energy Measurement	
Random Noise:	
HP 3563A Reading ($\sqrt{\quad}$)	
Voltmeter Average ()	% in-band energy
$\frac{\text{HP 3563A Reading}}{\text{Voltmeter Average}} \times 100 = \geq 70\%$	
Periodic Chirp:	
HP 3563A Reading ($\sqrt{\quad}$)	
Voltmeter Average ()	% in-band energy
$\frac{\text{HP 3563A Reading}}{\text{Voltmeter Average}} \times 100 = \geq 85\%$	

Installation

Incoming Inspection

The HP 3563A Control Systems Analyzer was carefully inspected both mechanically and electrically before shipment. It should be free of marks or scratches and in perfect electrical order upon receipt. Shipped with the analyzer is the power cord, (3) 16-bit probe cables, (3) 16-bit probe pods, (3) 8-bit probe cables, a pattern generator probe lead set, grabbers, a pouch and the documentation set.

Inspect the analyzer for physical damage which may have occurred during transit. If the analyzer was damaged in transit, save all packing materials, file a claim with the carrier, and call your Hewlett-Packard sales and service office.

Warning



If the analyzer is mechanically damaged, the integrity of the protective earth ground may be interrupted. Do not connect the analyzer to power if it is damaged.

Safety Considerations

The HP 3563A is a Safety Class 1 instrument (provided with a protective earth terminal). Although this instrument has been designed in accordance with international safety standards, this manual contains information, cautions and warnings which must be followed to ensure safe operation and retain the HP 3563A in safe operating condition. Service and adjustments should be performed only by qualified personnel who are aware of the hazards involved.

Warning



Before applying line power to the analyzer or testing its electrical performance, read this chapter.

Incoming Tests

Finish incoming inspection by testing the electrical performance of the analyzer using the operational verification tests in Chapter 3 or the performance tests in Chapter 4 of this Installation Guide. The operation verification tests verify the basic operating integrity of the analyzer; these tests take about two hours to complete. The performance tests verify that the analyzer meets all the performance specifications; these tests take about eight hours to complete.

Dimensions and Weight

Dimensions

Height:	222mm (8.75 in)
Width:	426mm (16.75i n)
Depth:	578mm (22.75 in)

Weight

27 kg (58 lbs)net
36 kg (79 lbs)shipping

Power Requirements

The analyzer can operate from a single-phase ac power source supplying voltages as shown in Table 5-1. With all options installed, power consumption is 450 Volt-amps.

The line-voltage selector switch is set at the factory to match the most commonly used line voltage of the country of destination; the appropriate fuse is also installed. To check or change either the line-voltage selector switch or the fuse see Figure 5-1, Table 5-1, and the following procedures.

Warning



Only a qualified service person, aware of the hazards involved, should measure the line voltage.

Caution



Before applying ac line power to the analyzer, ensure the line-voltage selector switch on the rear panel is set for the proper line voltage and the correct line fuse is installed in the fuse holder.

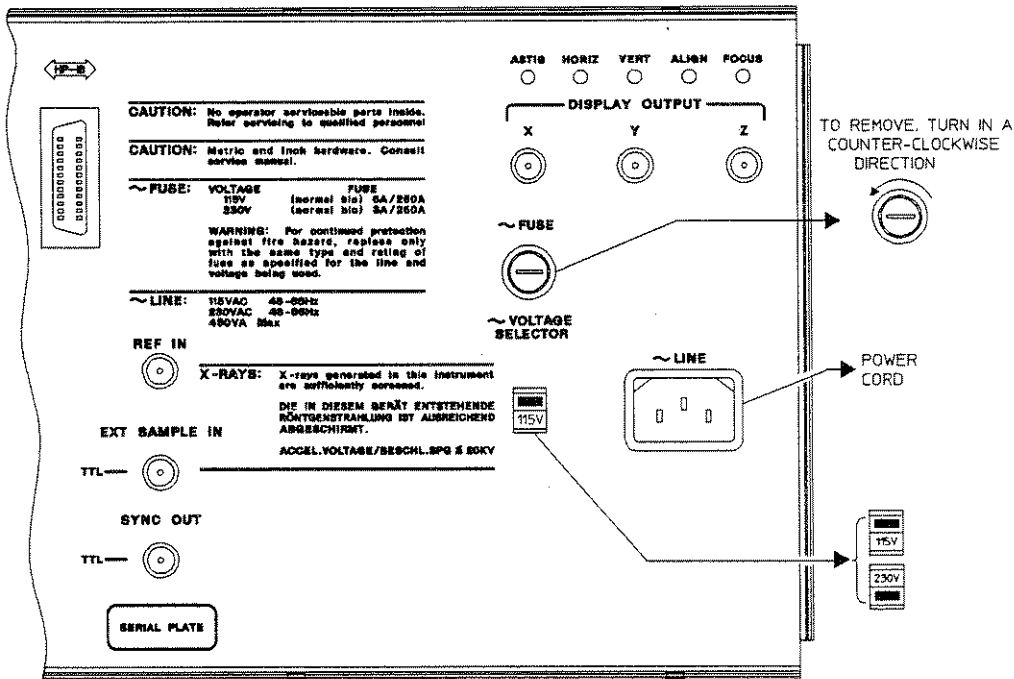

Figure 5-1. Voltage Selection and Fuse Replacement

Table 5-1. Line Voltage Ranges and Fuse Selection

AC Line Voltage		Selector Switch	Fuse	
Range	Frequency		HP Part No.	Type
86-127 Vac	48-66	115	2110-0056	6A/250V Normal Blo
195-253 Vac	48-66	230	2110-0003	3A/250V Normal Blo

To change the line voltage selector switch:

See Figure 5-1 and Table 5-1

1. Unplug the power cord from the analyzer.
2. Slide the Line Voltage Selector switch to the proper voltage.

To change the fuse:

See Figure 5-1 and Table 5-1

1. Unplug the power cord from the analyzer.
2. Using a small screw driver, turn the fuse holder cap to the left and remove (counter clockwise).
3. When the fuse cap is free from the housing, pull the fuse from the fuse holder cap.
4. Select the proper fuse and insert it into the fuse holder cap.
5. Insert the fuse holder cap and turn to the right (clockwise).

Power Cable and Grounding Requirements

Power Cable

The analyzer is equipped with a three-conductor power cord which grounds the analyzer when plugged into an appropriate receptacle. The type of power cable plug shipped with each analyzer depends on the country of destination. See Figure 5-2 for the available power cables and plug configuration.

Warning



The power cable plug must be inserted into an outlet provided with a protective earth terminal. Defeating the protection of the grounded analyzer cabinet can subject the operator to lethal voltages.

Installation

 <p>PLUG*: BS 1363A CABLE*: HP 5041-5811</p> <p>220V - 5A OPERATION</p>	 <p>PLUG*: NZSS 198/AS C112 CABLE*: HP 5041-5805A</p> <p>220V - 6A OPERATION</p>
 <p>PLUG*: CEE7-V11 CABLE*: HP 5041-5810</p> <p>220V - 6A OPERATION</p>	<p>NORTH AMERICA</p>  <p>PLUG*: NEMA 5-15P CABLE*: HP 5041-5820</p> <p>250V - 10A** OPERATION</p>
 <p>PLUG*: NEMA-G-15P CABLE*: HP 5041-5806</p> <p>250V - 6A** OPERATION</p>	<p>JAPAN</p>  <p>PLUG*: MITI 41-9692 CABLE*: HP 5041-5839</p> <p>125V - 12A OPERATION</p>
 <p>PLUG*: SEV 1011.1959-24507 TYPE 12 CABLE*: HP 5041-5813</p> <p>220V - 6A OPERATION</p>	 <p>PLUG*: DHCR 107 CABLE*: HP 5041-5815</p> <p>220V - 6A OPERATION</p>

Figure 5-2. Power Cables and Plug Configurations

*The number shown for the plug is the industry identifier for the plug only; the number shown for the cable is an HP part number for a complete cable including the plug.

**UL listed for use in the United States of America.

Grounding

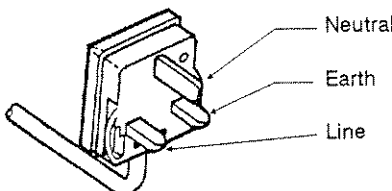
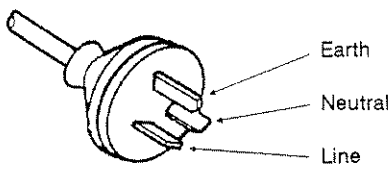
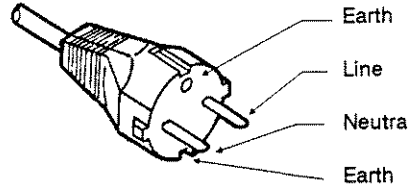
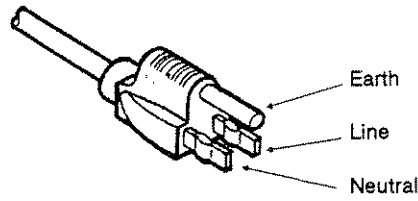
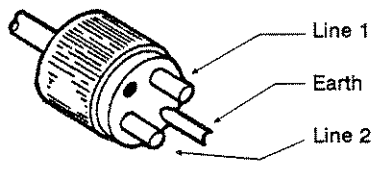
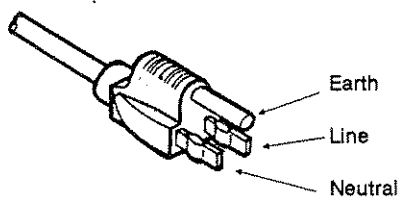
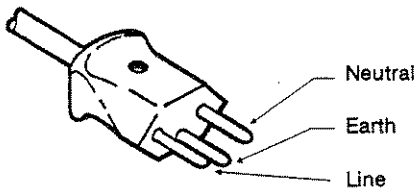
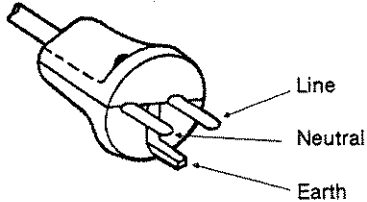
The HP-IB connector pin 12 and pins 18 through 24 are tied to protective earth ground and the HP-IB cable shield. The instrument frame, chassis, covers, and all exposed metal surfaces, are connected to protective earth ground. The outer conductor of the analog BNCs, Channel 1 and Channel 2, is **NOT** connected to protective earth ground, and can be raised to a maximum of 42 Vpk with respect to instrument chassis.

Warning



Do **NOT** interrupt the protective earth ground or “float” the HP 3563A. This action could expose the operator to potentially hazardous voltages

Operator Maintenance

Operator maintenance is limited to setting the voltage selection, replacing the line fuse (described in a previous section, Power Requirements), cleaning the fan filter, and if necessary, cleaning the display. There are no operator controls or user-serviceable parts inside the HP 3563A. Only trained service personnel should perform instrument repairs.

Warning



Under no circumstances should an operator remove any covers, screws, or in any other way enter the HP 3563A. There are no operator controls inside the HP 3563A.

Cleaning the Air Filter

The cooling fan's air filter is located on the rear panel. To service the filter, remove the power cable and remove the four knurled nuts that hold the filter to the rear panel. Clean the filter using a solution of warm water and a mild soap or replace the filter, HP 3150-0218.

The air filter should be cleaned every 30 days.

Cleaning the Display (CRT)

The analyzer display is not removable by the operator. Under normal operating conditions the only cleaning required will be an occasional dusting with a soft brush. A household-type tack cloth, or other type of lint remover, may also be used.

However, if a foreign material adheres itself to the display; remove the power cable, dampen a soft, lint-free cloth with a mild detergent mixed in water, and carefully wipe the display.

To prevent damage to the display, do not use cleaning solutions other than the above.

Warning



Do not apply any water mixture directly to the display or allow moisture to go behind the front panel. Moisture behind the front panel will severely damage the instrument.

Analyzer Cooling

Cooling air enters the analyzer through the rear panel and exhausts through the side panels. Install the analyzer to allow free circulation of cooling air.

Installation

The analyzer is shipped with plastic feet in place, ready for use as a bench analyzer. The plastic feet are shaped to make full-width modular instruments align when they are stacked.

To install the analyzer in an equipment cabinet, follow the instructions shipped with the rack mount kit, option 908.

Turning on the HP 3563A

Caution



Before applying ac line power to the analyzer, ensure the line-voltage selector switch on the rear panel is set for the proper line voltage and the correct line fuse is installed in the fuse holder. See the previous section, "Power Requirements".

Apply proper line power to the analyzer. Press the rocker-switch in the lower left-hand corner of the analyzer to the ON position, (I). The analyzer requires a minute to warm up and self-calibrate.

When using the analyzer for the first time, run the analyzer self test to ensure proper operation (see Chapter 3, "Operation Verification Tests").

For additional measurement information or other operating information, see the *HP 3563A Getting Started Manual*.

HP-IB System Interface Connections

The analyzer is compatible with the Hewlett-Packard Interface Bus (HP-IB). The HP-IB is Hewlett-Packard's implementation of IEEE Standard 488.2. The analyzer is connected to the HP-IB by connecting an HP-IB interface cable to the connector located on the rear panel. Total allowable transmission path length is 2 meters times the number of devices or 20 meters, whichever is less. Operating distances can be extended using an HP-IB Extender.

For additional information about HP-IB programming see the *HP 3563A Programming Reference*.

Labeling the Digital Probes and Cables

Labels for the digital probes and cables have been provided to aid in the setup of digital measurements.

Labeling the Input Cables

Qualifier Pod, Input Pod 1 and Input Pod 2

1. Refer to Figure 5-3.
2. Install the Cable labels shown as #1 in Figure 5-3. Four labels are provided so you can mark both ends of the cable.
3. Install the Pod label shown as #2 in Figure 5-3.
4. Install the Pod Pinout label shown as #3 in Figure 5-3.
5. Install the Probe Tip labels, shown as #4 in Figure 5-3, to match the pinouts on the Pod Pinout label (#3).

For example, the third pinout on the right of the Qualifier Pod cable is the TRG pinout. Place the TRG Probe Tip label on the corresponding third probe tip from the right.

6. Repeat steps 1 - 5 for the remaining Input Pods, Input Pod 1 and Input Pod 2.

Note



Please note the second position from the right is GROUND, GND. X OVF on the Probe Tip label refers to OVF on the Pinout label of the Qualifier Pod.

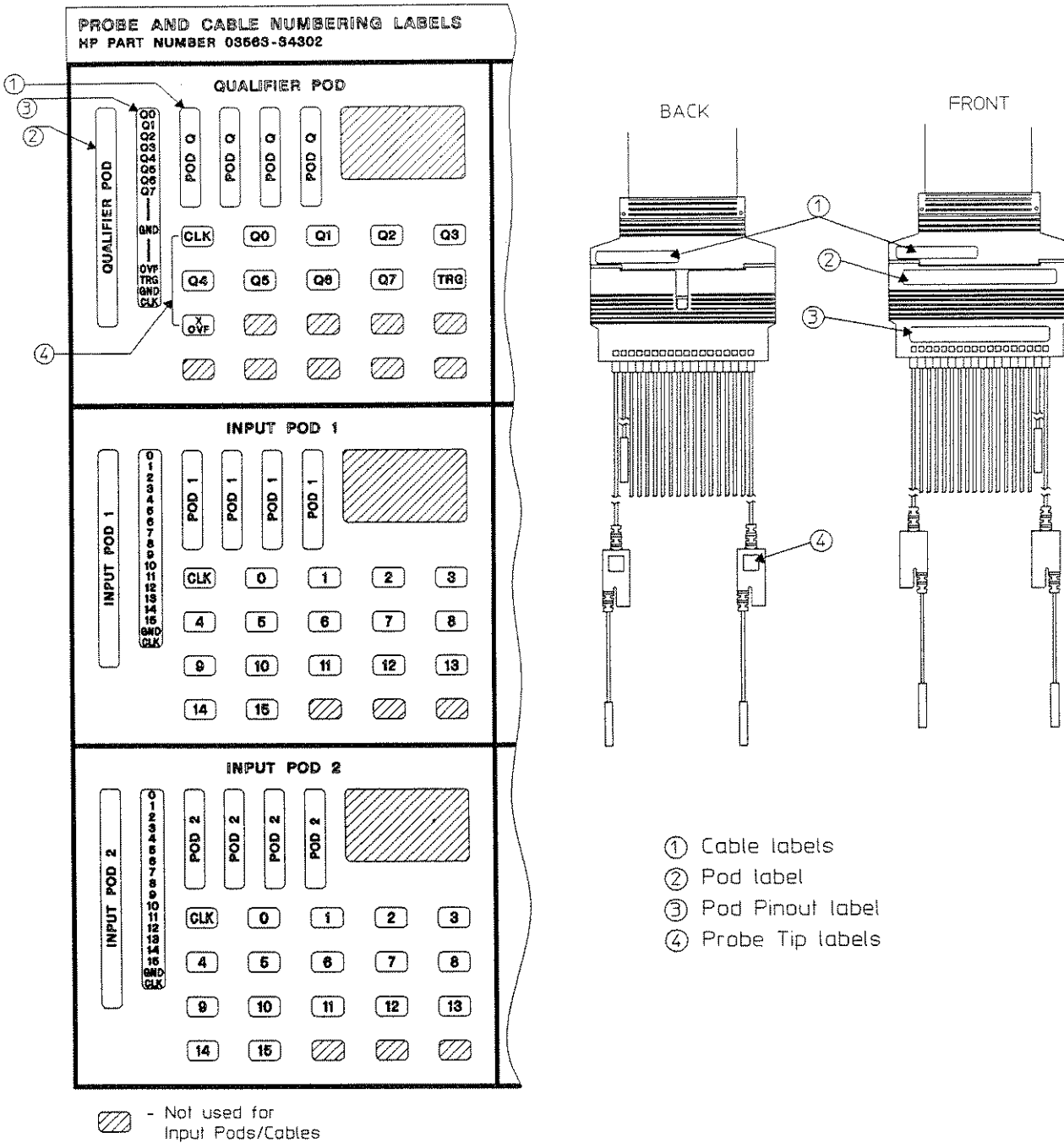

Figure 5-3. Input Probes, Cable and Labels

Labeling the Output Cables

Pod X, Source Pod MSB and Source Pod LSB

1. Refer to Figure 5-4.
2. Install the Pod Pinout label shown as #1 in Figure 5-4.
3. Install the Probe Tip labels, shown as #2 in Figure 5-4, to match the pinouts on the Pod Pinout label (#1).

For example, the third pinout on the right of the Pod X is the SCE END pinout. Place the SCE END Probe Tip label on the corresponding third probe tip from the right.

4. Repeat steps 1 - 3 for the remaining Source Pods, Source Pod MSB and Source Pod LSB.

Note



We recommend disconnecting the excess ground probe tips on Pod X and the Qualifier Pod, Pod Q.

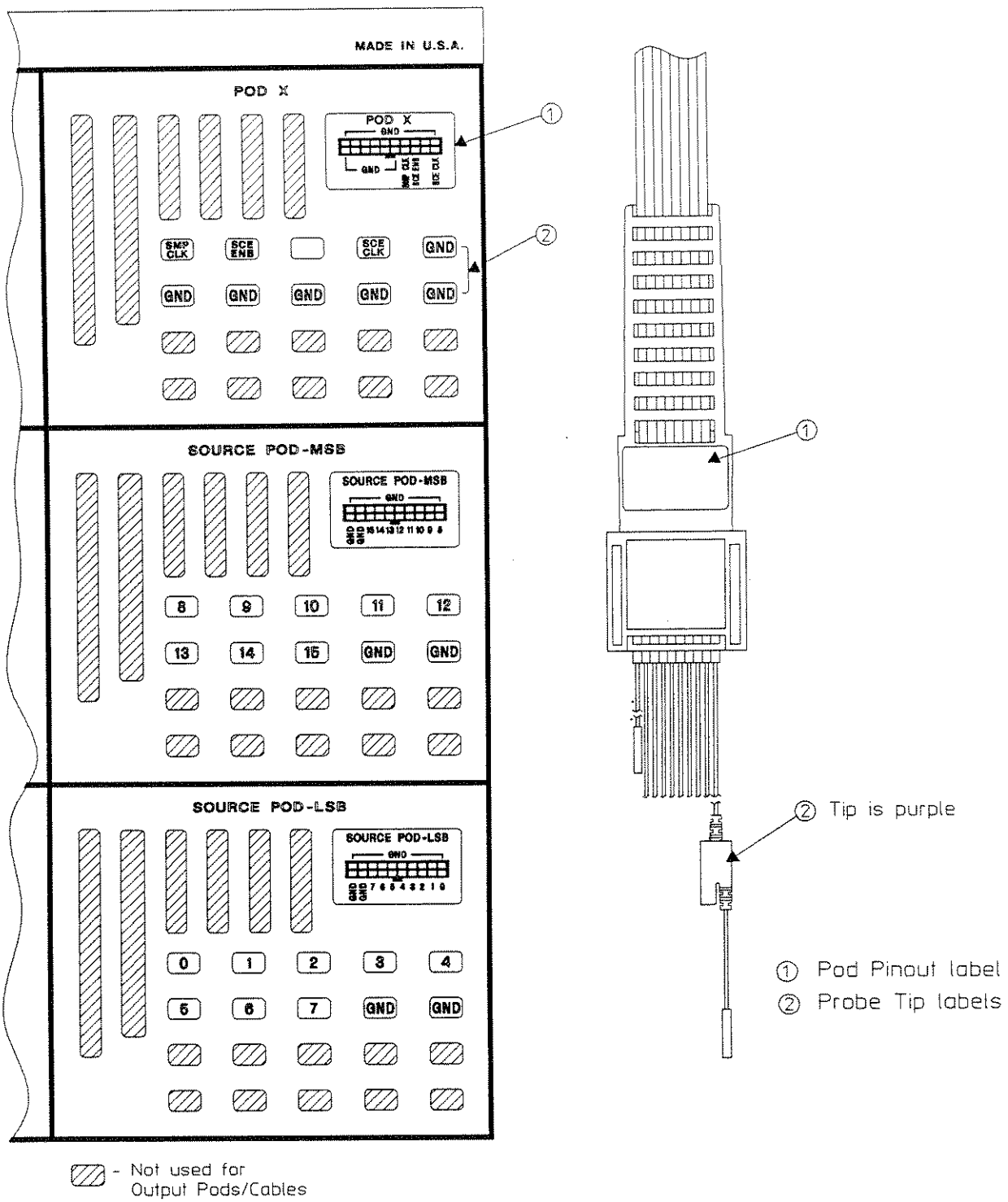

Figure 5-4. Output Cables, Pods and Lables

Operating Environment

The operating and storage environment specifications for the analyzer, are listed below. Specifications apply when AUTO CAL is enabled or within 5°C and 2 hours of last internal calibration.

Ambient Temperature:	0° to 55° C
Relative Humidity:	≤ 95% at 40 °C
Altitude:	≤ 4570m (15,000ft)

Warning



To prevent potential fire or shock hazard, do not expose the analyzer to rain or other excessive moisture.

Protect the analyzer from moisture and temperatures or temperature changes which cause condensation within the analyzer.

Storage and Shipment

Storage

Store the analyzer in clean, dry and static free environment. Additional environmental specifications are listed below:

Temperature: -40° to $+75^{\circ}$ C
Altitude: ≤ 15240 m (50,000ft)

Shipment

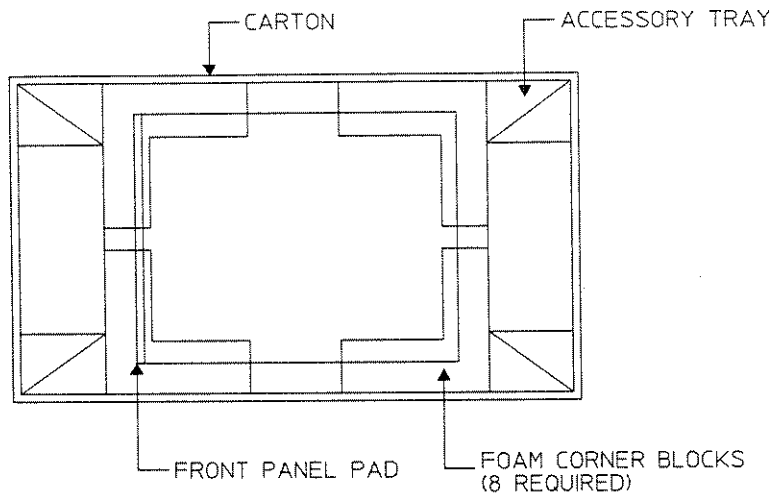

Figure 5-5. Repackaging for Shipment

We recommend saving the original packing material. If this is not possible and the analyzer needs to be returned, containers and materials identical to those used in factory packaging are available through Hewlett-Packard sales offices and the factory. See Figure 5-5.

If the analyzer is being returned to Hewlett-Packard for service, attach a tag describing the type of service required, the return address, model number and full serial number. Also mark the container **FRAGILE** to ensure careful handling. In any correspondence, refer to the analyzer by model number and full serial number. (See Chapter 1 for more information about the analyzer's serial number.)

